



THESIS PORTFOLIO

AIM

- To create a working environment aesthetically appealing interactive, creative and inspiring platforms for various professionals pertaining to fashion industry.
- To make it comfortable for the employees to work in and the clients to visit.
- To understand all the processes involved in fashion technology with its own characteristics spatial requirements.
- Understanding the functional hierarchy of the entire space yet not undermining the design of each section and their arrangement

OBJECTIVES

- To develop a fashion studio that has mix of fashion, business, entertain, culture and leisure and powerful identity.
- To develop a space that is synonymous to fashion, a statement of time..
- To incorporate spaces that will help that will nurture and help the upcoming fashion designers providing them with marketing support
- To provide a good working environment for the creation, workshop, exhibition to provide an interactive place.
- To provide facilities for conducting research into various foreign fashions and its trends in order to keep abreast with fast moving fashion sense.

SCOPE AND LIMITATIONS

- Creates a distinctive icon for fashion in a city thus a landmark is created.
- It will provide an interface by creating a permanent market and event place for fashion industry.
- Highlighting the Indian traditions and culture identity,
- It also influences the aesthetic, theory, technology and history.
- It also helps with the creating awareness about the current trends and also about the sustainable clothing.

INTRODUCTION

Fashion hub is a meeting point for all the major activities related to fashion. It is an amalgamation of retail spaces, exhibition area, museum, library, conference room seminar rooms, office, production units, ramp show areas, food court, boarding facilities etc

Fashion is the prevailing style, custom or a popular style in clothes, hair accessories, footwear etc. of a particular type or place. Business of making or selling clothes in new and different styles is also fashion, varies from village to village, city to city.

REQUIREMENTS

- Administrative office
- Design and production workspaces
- Event areas
- Photography studio
- Fashion, exhibition and modeling Gallery
- conference hall
- Makeup area
- Food corner, restrooms and toilets
- Landscape - indoor and outdoor

NEED OF THE STUDY

- To develop a space that is synonymous to fashion, on a statement of time
- Create a small one stop for fashion related activities and information in a provided place for various sectors of people-exhibitors, fashion designers, speculators, common public etc.
- To give the Indian fashion business grand leap Hence, the project is an attempt to make people aware about the fashion and the process, and produce respect for the same.

HISTORY OF INDIAN FASHION

History of clothing in the Indian subcontinent can be traced to the Indus Valley civilization or earlier. Indians have mainly worn clothing made up of locally grown cotton. India was one of the first places where cotton was cultivated and used even as early as 2500 BCE during the Harappan era. The remnants of the ancient Indian clothing can be found in the figurines discovered from the sites near the Indus Valley civilisation, the rock-cut sculptures, the cave paintings, and human art forms found in temples and monuments. These scriptures view the figures of human wearing clothes which can be wrapped around the body. Taking the instances of the sari to that of turban and the dhoti, the traditional Indian wears were mostly tied around the body in various ways.

METHODOLOGY

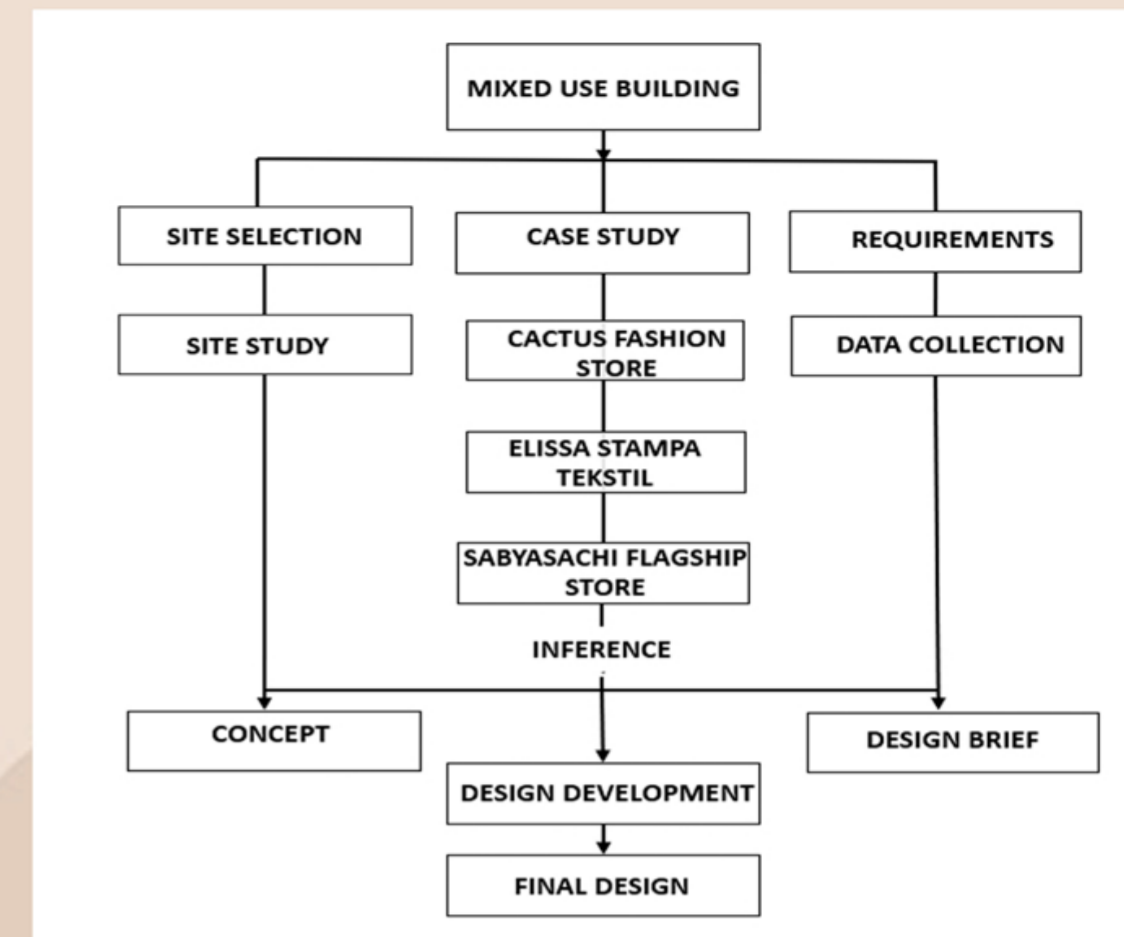

CASE STUDY



CACTUS FASHION STORE
CHINA



ELISSA STAMPA TEKSTIL
ISTANBUL, TURKIYE



SABYASACHI FLAGSHIP STORE
NEW DELHI

SITE - KOCHI



Vyttila hub: 11 km
NH 47 : 4 km
Airport : 9km
Railway station : 9km

Location : old glass factory site south
kalamassery Ernakulam

Area : 14000 sqf

kalamassery is an industrial zone located in Kochi and a very developed area in Kochi and also a middle ranged developed city with quick access to all other facilities like NH road, airport, train, metro all facilities the site is located in a non-busy road and with all other facilities like electrical water drainage.

Kalamassery is a space in Kochi where now a time fastly developing an Kochi is a land of so much other events and activities occurring and more people's traffic blocks etc

in kalamassery this site is so vast and has many accessibilities and also all the Kochi influence and the site is having a good surrounding view

DATA COLLECTION

RECEPTION

Reception area is a section of office space that is used to greet all visitors and provide a waiting area for them until they are met by the person that they came to meet with.

The reception is the part of a company that comes in contact with clients, such as the marketing, sales and service department.

RECEPTION CONSIST OF :

- Reception desk/station
- A comfortable and ergonomically appropriate chairs for the receptionist
- Chair for guests to use while waiting.
- A table to hold literature or magazine or to provide a surface of visitors for their purpose their briefcase, or other personal belongings while waiting.

WIDTHS OF HORIZONTAL CIRCULATION

Primary circulation 1.5-2.0m.sq
 Secondary circulation 0.9-1.5m.sq
 Tertiary circulation 0.55-0.75m.sq
 Lift lobbies 3.0m.sq

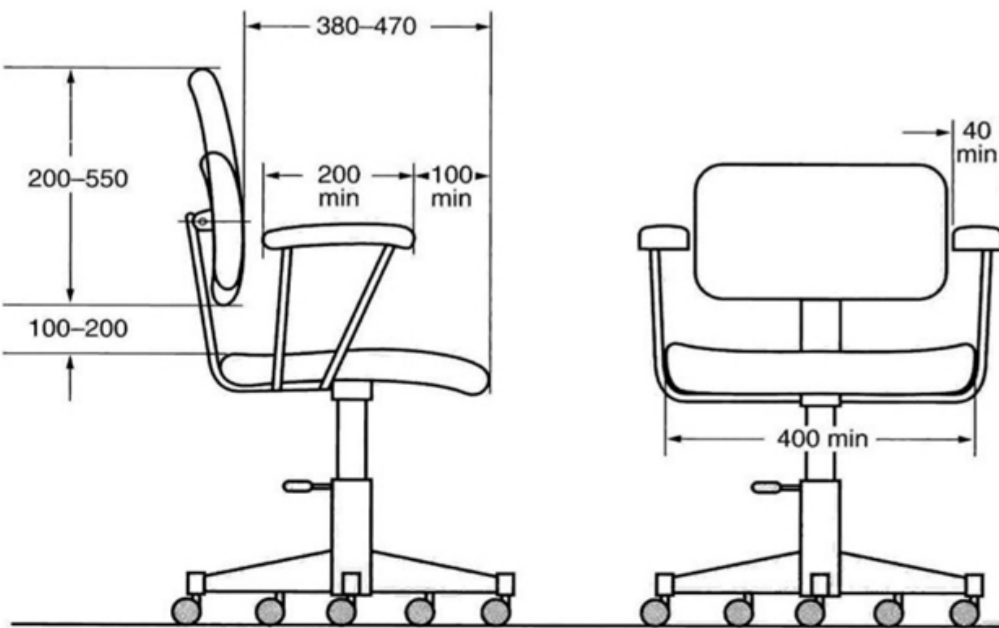
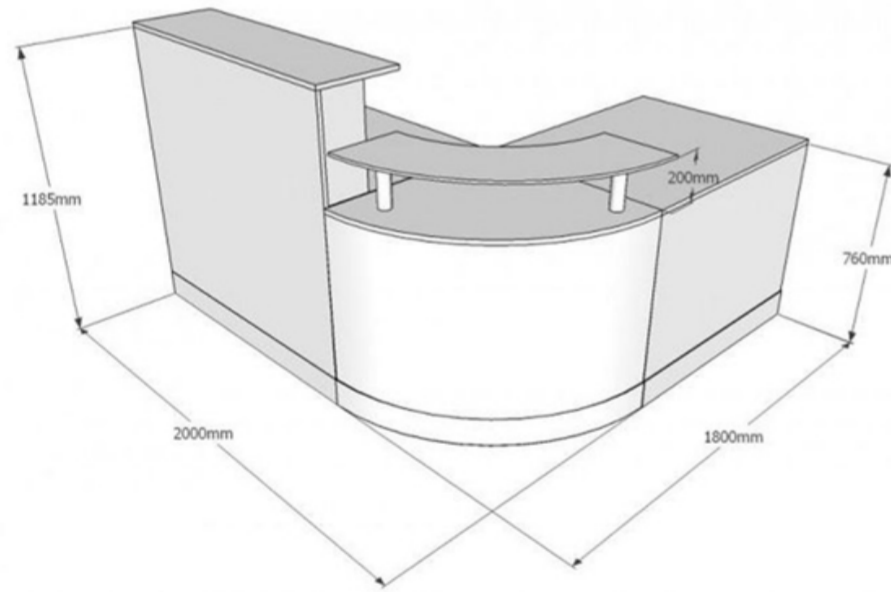

WAITING AREA

- Waiting area may include chairs, codes storage display materials, child play area, public access, work stations
- Individual seats are preferred over sofas
- Corner seatings arrangement must always consider leg clearance
- Circulation between low tables and the edge of chairs must be adequate to allow for the legs of persons seated in the chairs
- Convenient location for side tables, so that magazines, ashtrays, artwork or portable lighting can be placed on them

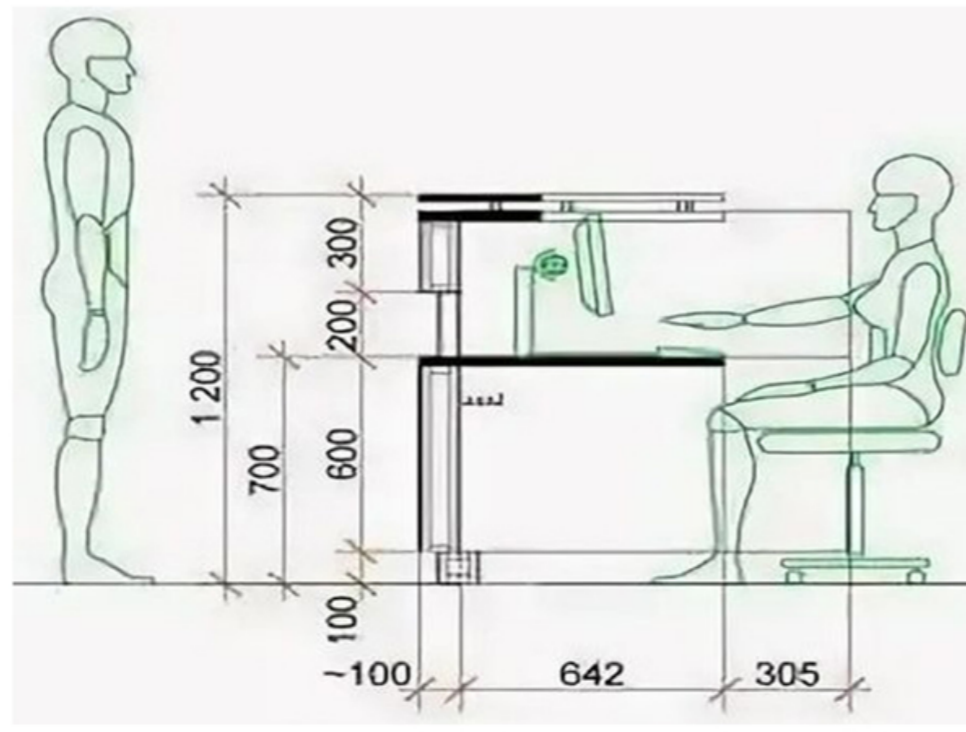
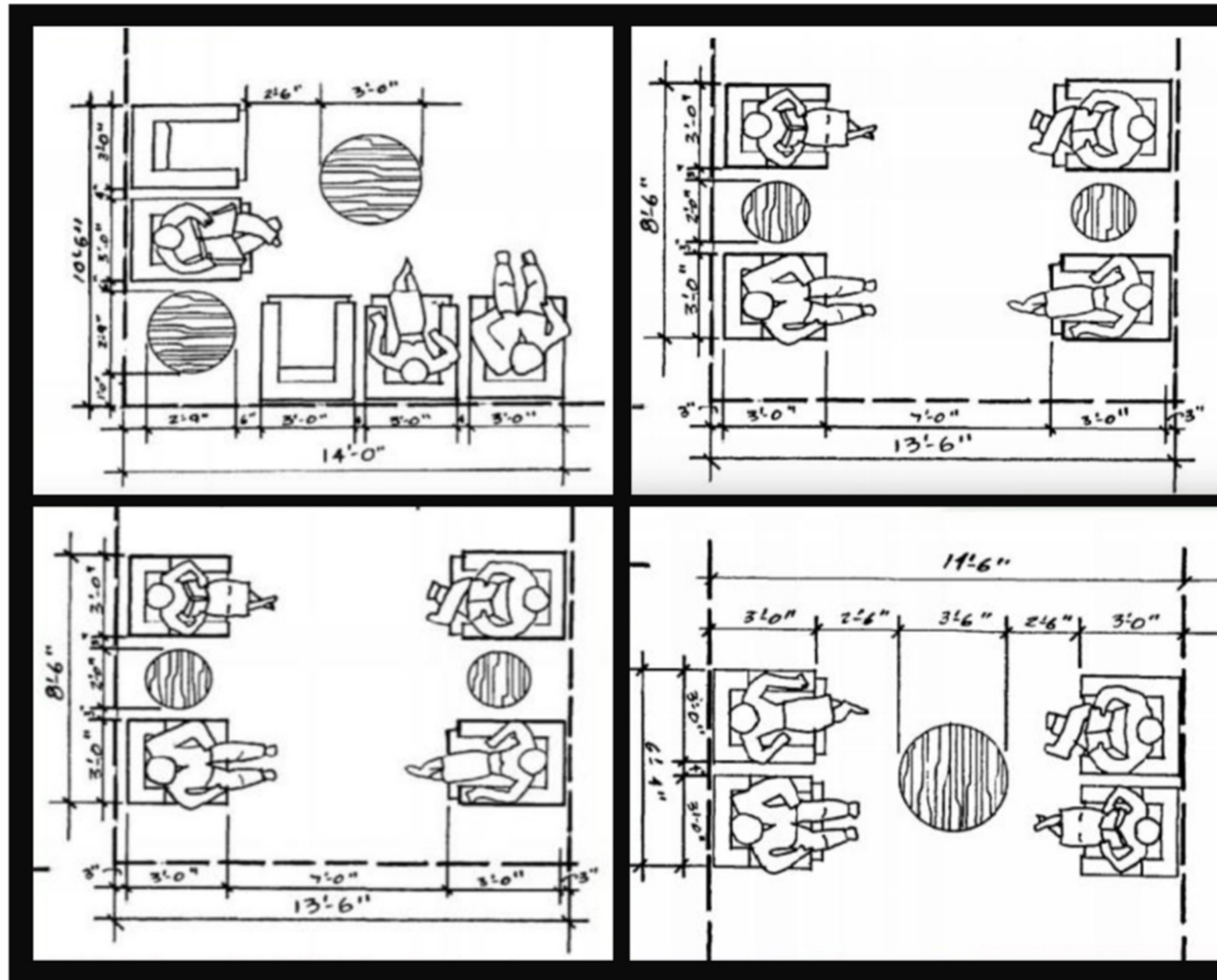

WORK STATIONS WITH VISITORS

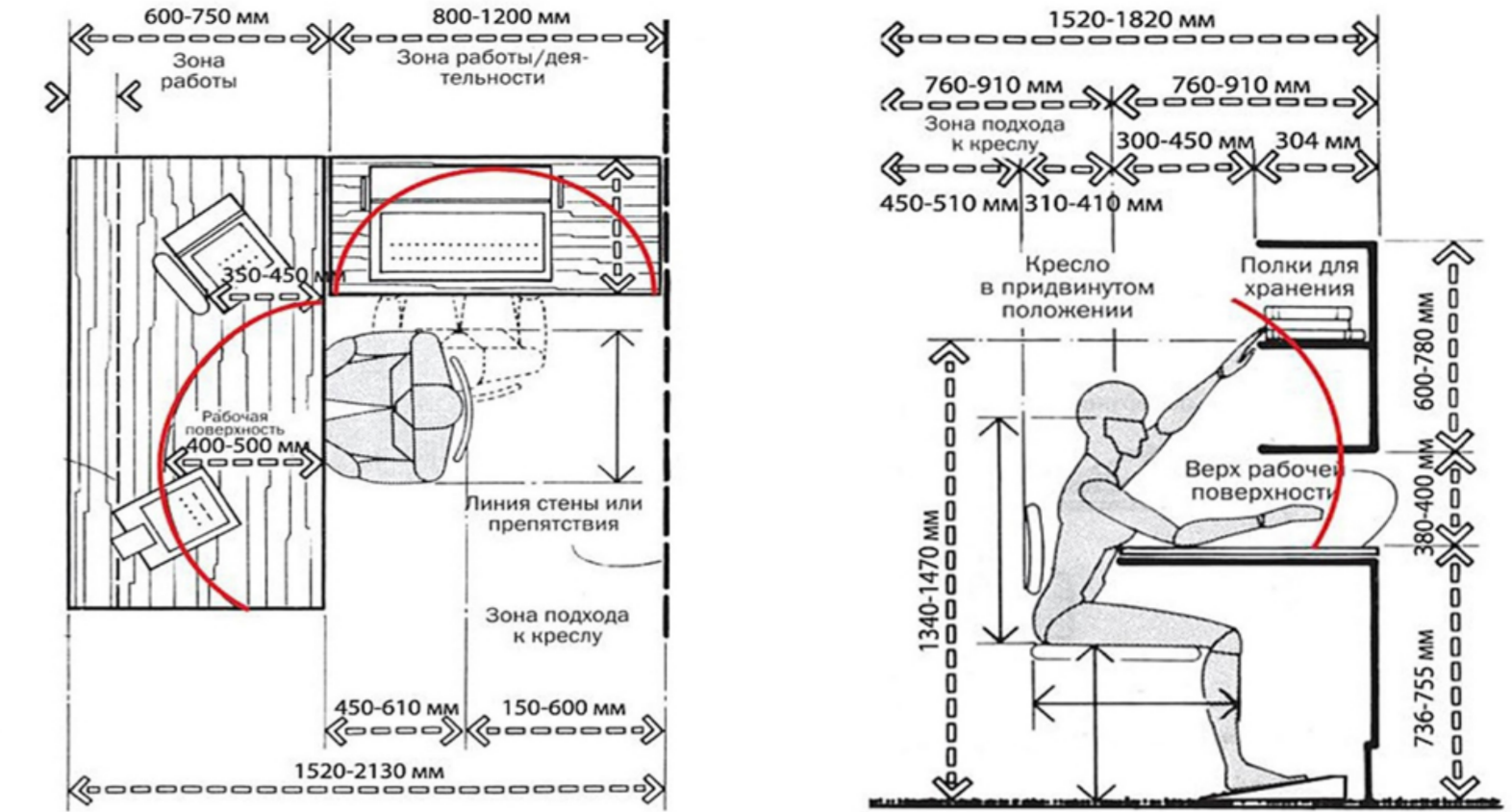

CABINS

- Cabins can either be open or close.
- Cabins can either be made of glass or wood.
- As most companies look to activate team players so they don't believe in providing closed rooms to each employee.
- These cubicles provide them a separate place to work peacefully and also keep them connected with colleagues.
- On the other hand, closed glass cabins are usually utilized for meetings. Such open view cabins are known to trigger new ideas, business strategies and important discussions.

WORK STATIONS

- Work station can be different sizes and shapes and normally will have partition in front of the desk with certain feet of height.
- Work station can be designed for individual works and for group work.
- This work stations helps in easy ac-cesseability between different employees and probably used by managers, team leaders.
- The surface has also different coating of material.

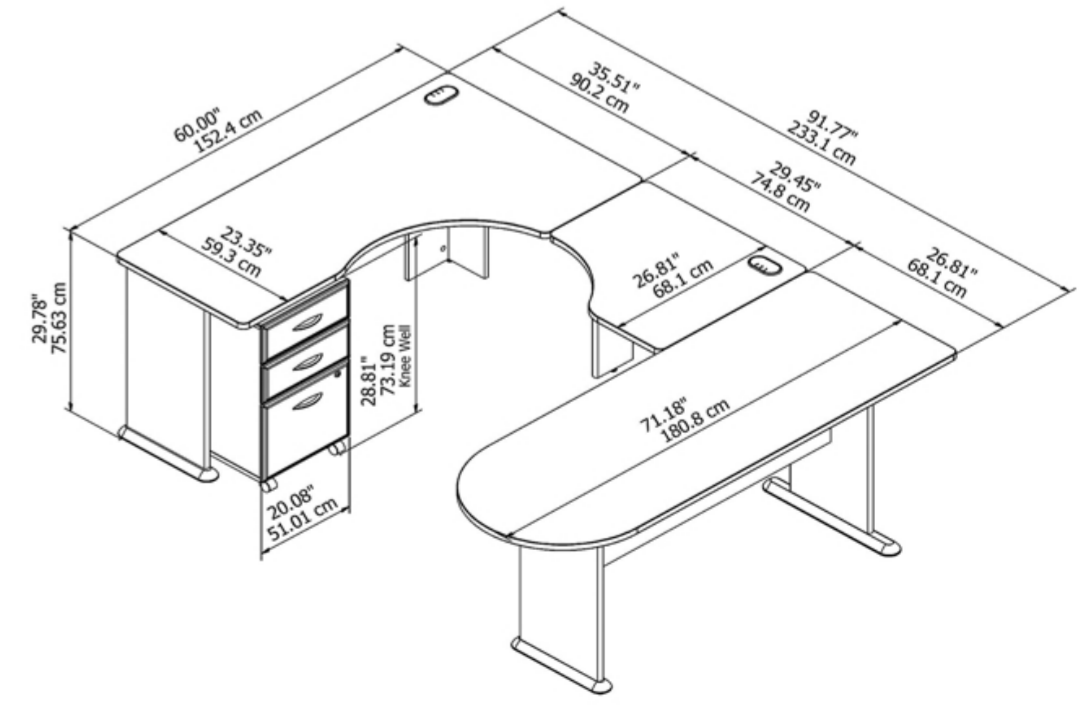

MULTIPLE WORK STATIONS

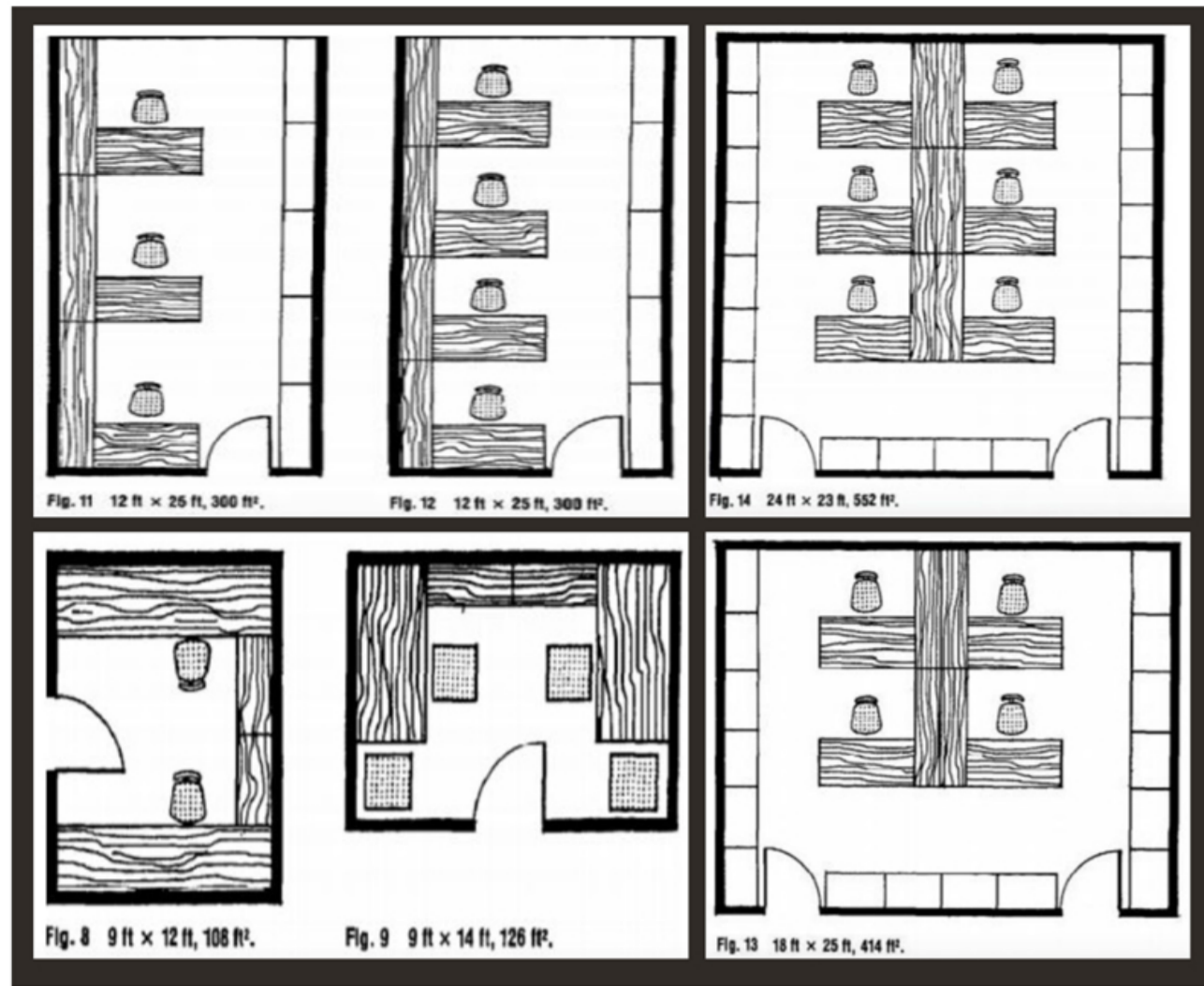

STORAGE

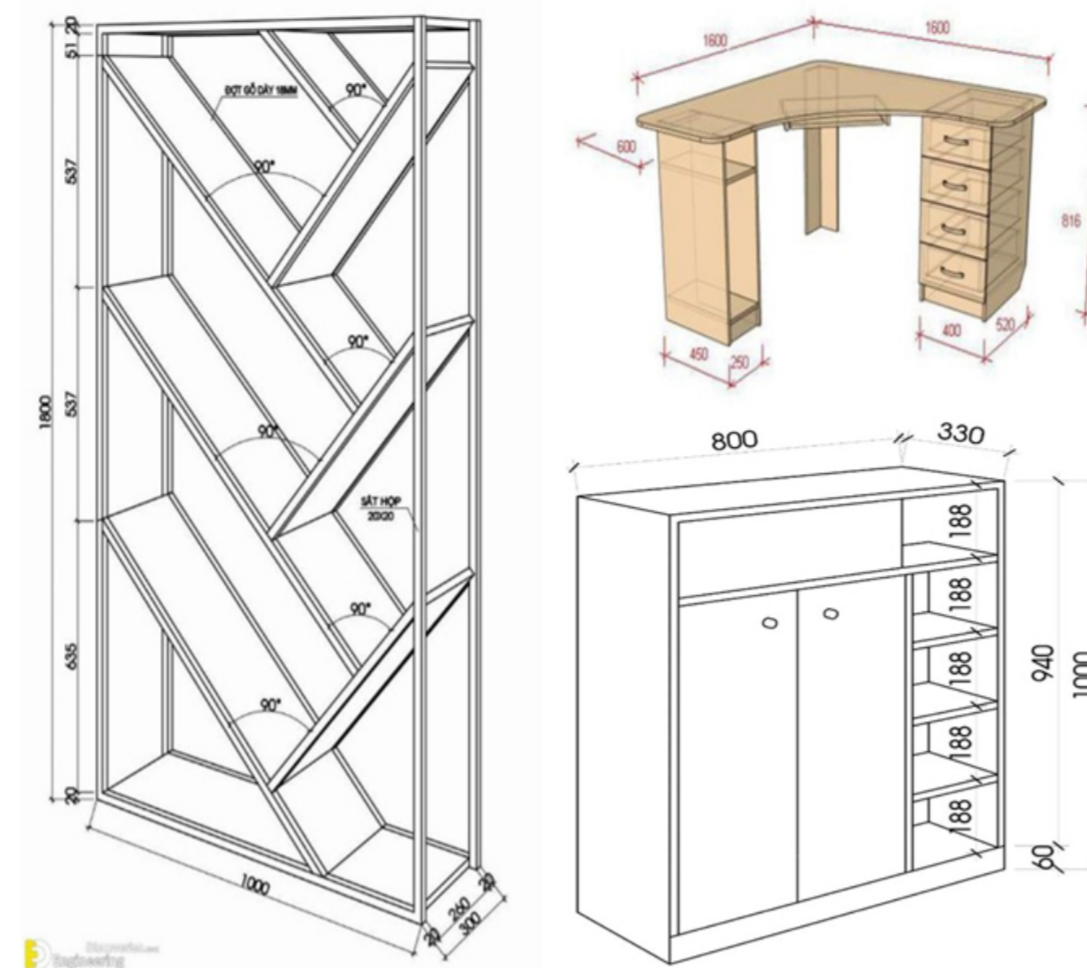

RUNWAY DIMENSIONS

Length - One rule of thumb in designing a fashion runway is that the length is generally two-thirds the length of the room.
 Width - the width of the stage can be 4' to 8' to 12' depending on the number of models or the setting of stage.

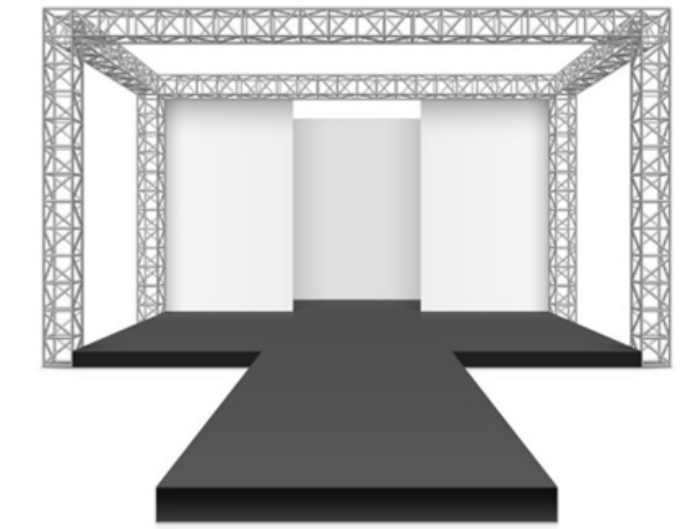

- Minimum width - 4'
- Maximum width - 12'
- Height - the height is either on ground level or 2'- 6'
- For smaller fashion shows a 4' wide runway is a suitable size. It provides room for a single line of models. It is designed for small scale shows to provide a quality stage to fit the needs.
- The 6' wide runway allows for better flow for models by providing room for two models simultaneously. although it is smaller in scale, the stage can be accompanied with a 'T' to top it off and make plenty of room for a final finale.
- The 8' wide runway is great for larger shows that have great models. This runway is designed for larger companies that want to put on a great show.

PRIVATE OFFICES

Private offices provide an atmosphere of status to employees who are provided that type of space. Typically, those in a position of authority will get a office or a large office through promotion. It is a status symbol that has been in the business world for centuries, and many employees still use it as a major career milestone. Industries where climbing ladders is essential would benefit the most from these office design ideas.

To design of the private office requires a knowledge the basic dimensional requirements and clearances of the executive work station and where applicable of visitors seating accommodations.

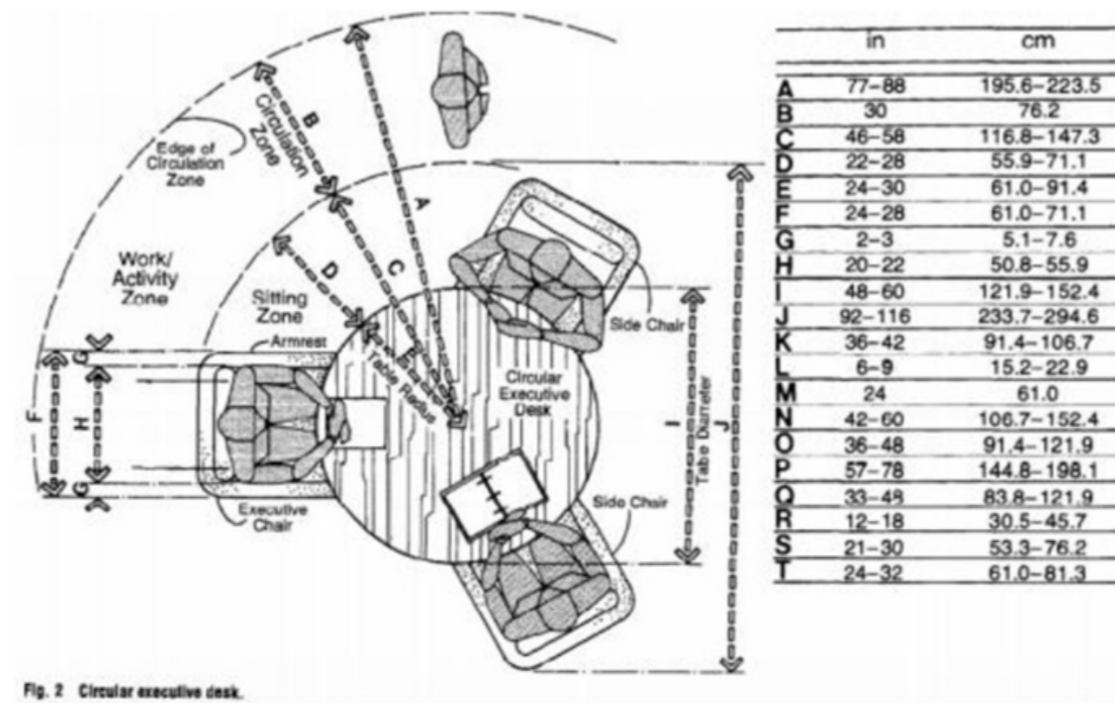
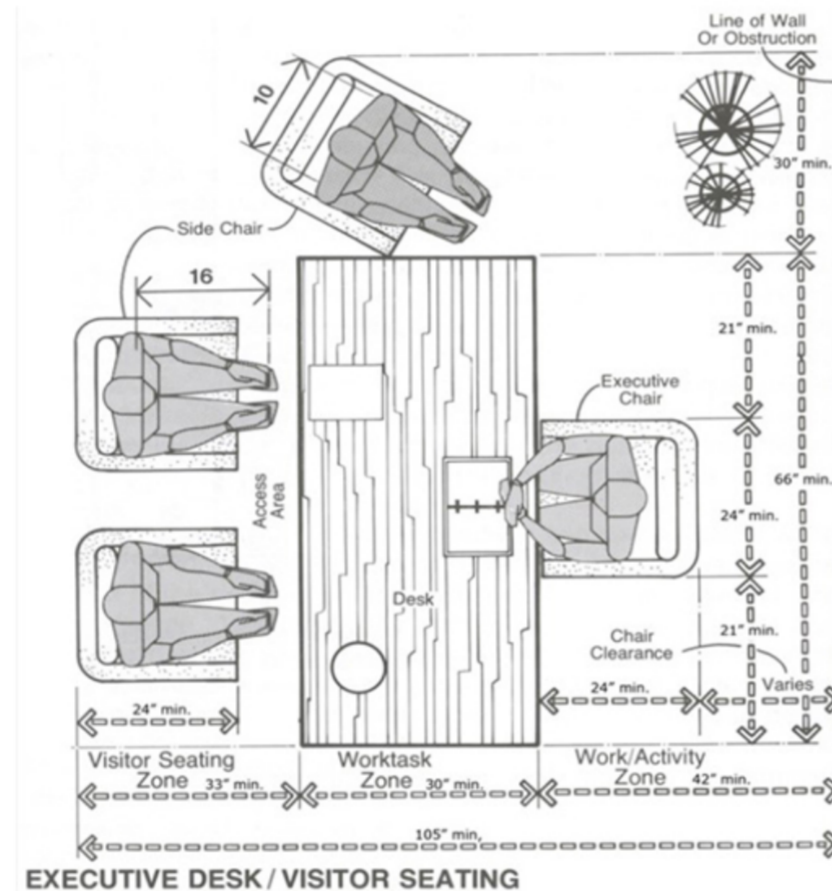
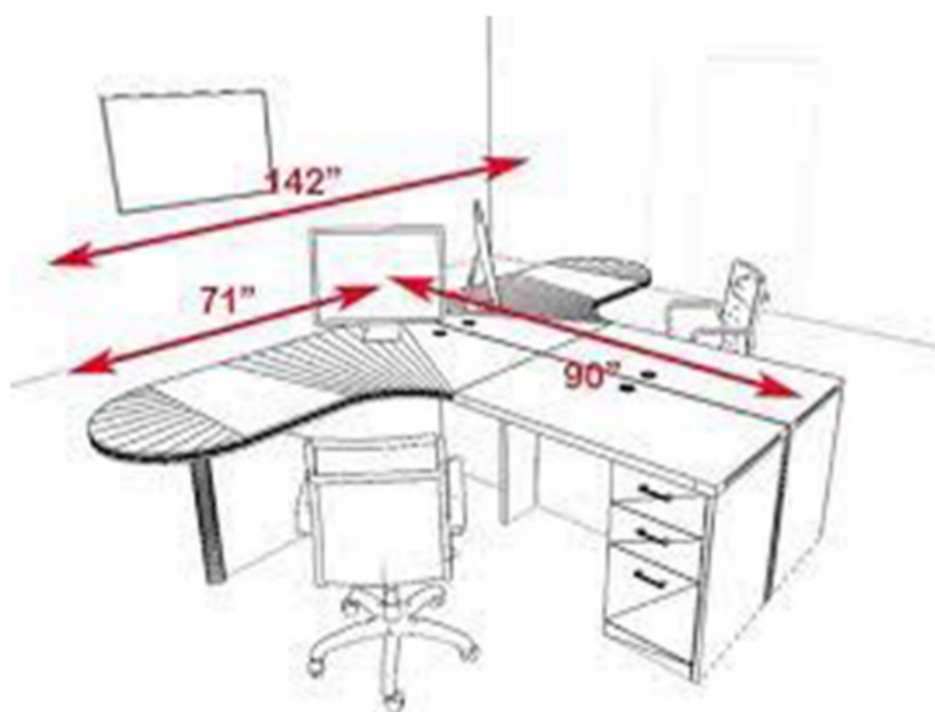

CONFERENCE ROOM

Conference rooms are for conference call, board meeting, management discussion and major discussion making situations. They are some of the most elaborate meeting rooms in an office both in term of AV gear and furniture.

CONFERENCE ROOM EQUIPMENT

- White board with pens
- The right chairs and tables
- The right projector and viewport, is their anything annoying then known functioning technology.
- Tables and cords
- Functioning AV equipment.
- Audio or video conferencing equipment.
- A coffee maker and hot water boiler for tea.

CONFERENCE ROOM LAYOUT

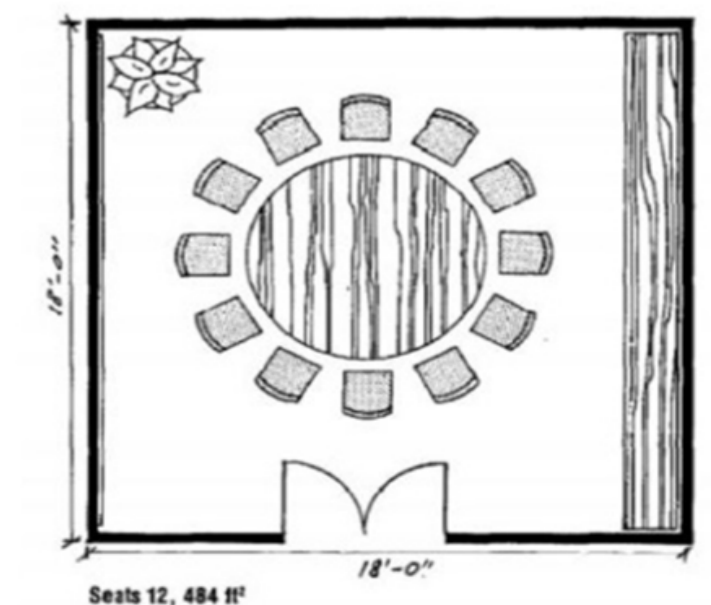
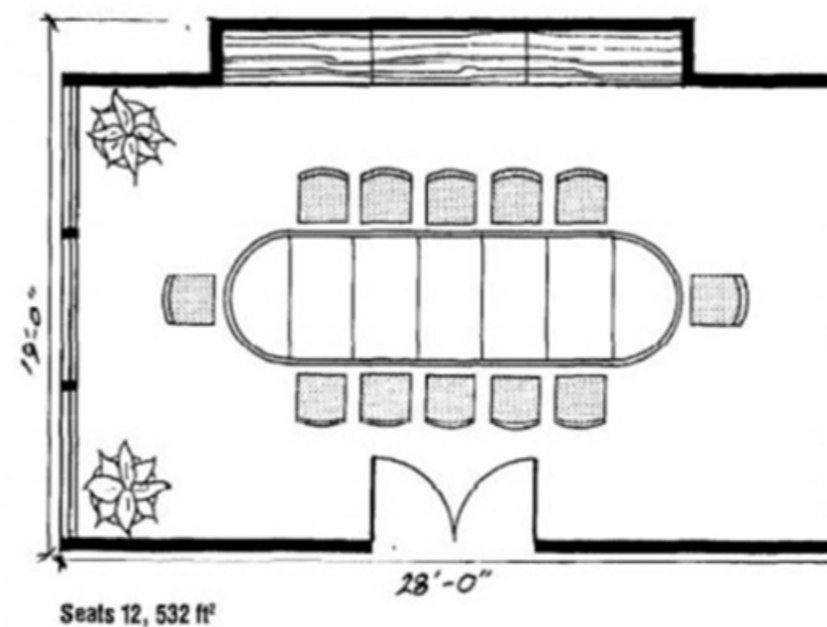
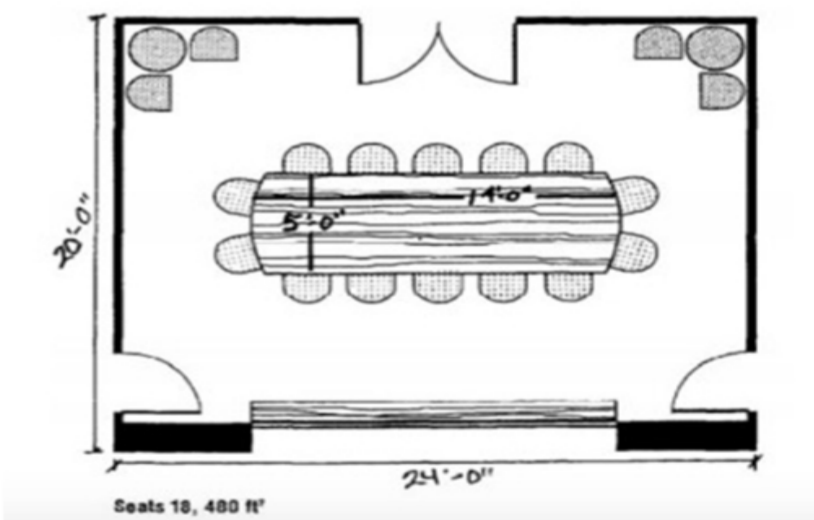
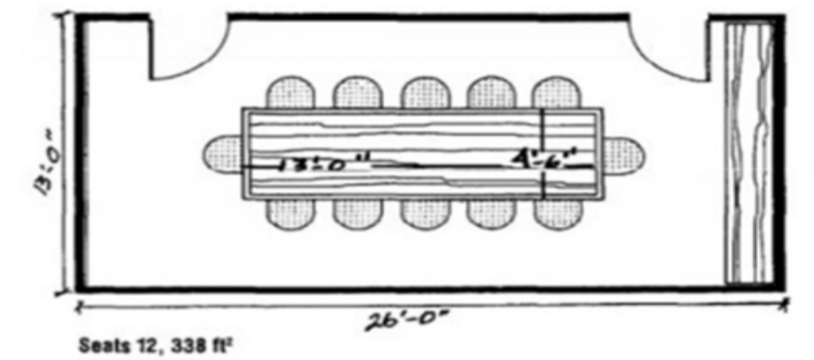

DATA COLLECTION

CACTUS FASHION STORE

INTRODUCTION

CACTUS, a clothing brand, has a concept retail store in Xi'an china. The client expects it to be pink and romantic. Designed by Boundary space design Area-260m sq inaugurated by 2019.



SITE DETAILS

It was a north facing two-story store on the corner, with a cluttered neighborhood and old front steps. The first and second floor areas of it were 40m sq and over 200m sq.

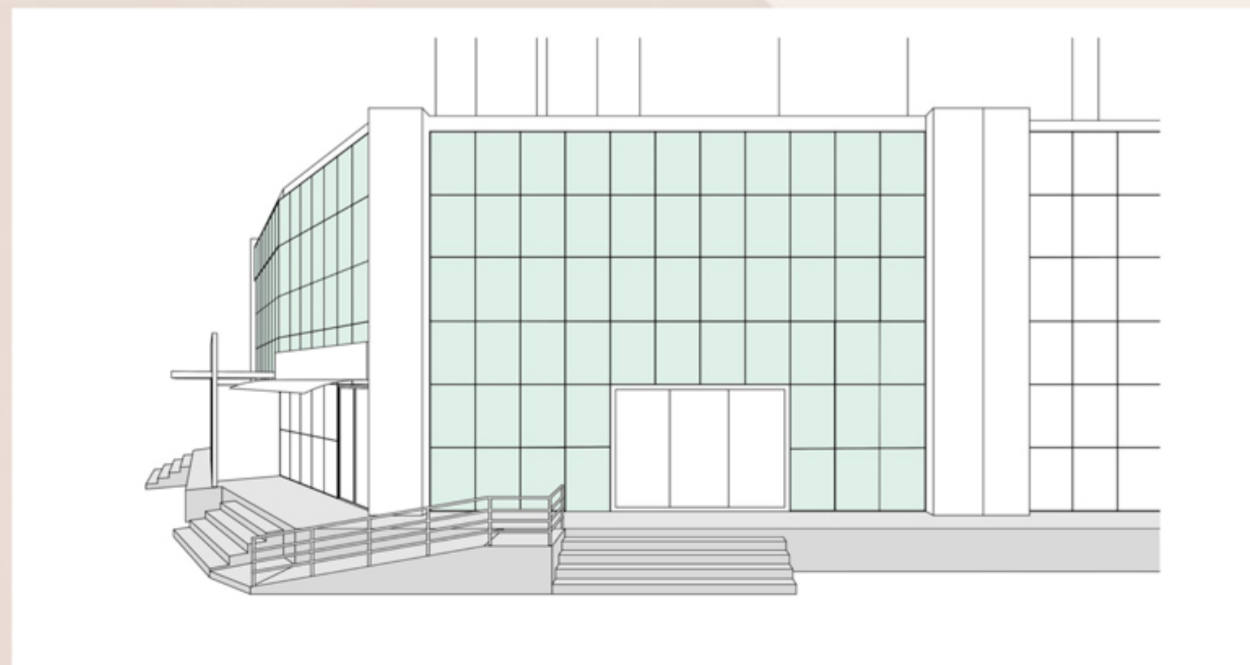

with its limited width, the ground floor space assumed the role of guiding and channeling guests from to inside and from down-stairs to upstairs.

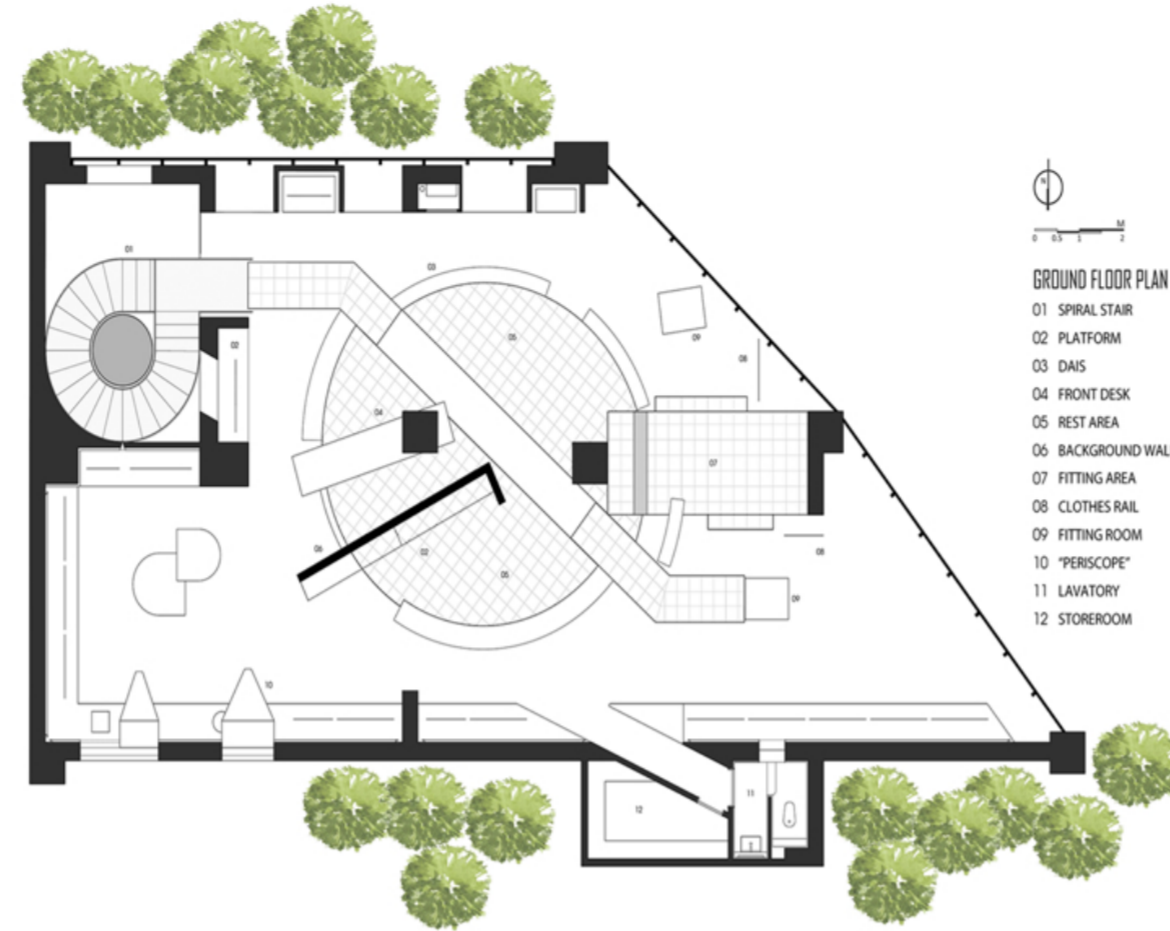

- GROUND FLOOR PLAN
- 01 SPIRAL STAIR
 - 02 PLATFORM
 - 03 DASH
 - 04 FRONT DESK
 - 05 REST AREA
 - 06 BACKGROUND WALL
 - 07 FITTING AREA
 - 08 CLOTHES RAIL
 - 09 FITTING ROOM
 - 10 "PERISCOPE"
 - 11 LAVATORY
 - 12 STOREROOM

Second floor, there were large L-shaped windows and open spaces along the street. The green glass on the aluminum grid wall blocked the view, and the space was abruptly cut by several large square columns.

Two high windows at the southwest corner gave a view of the windows of the disordered residential area.

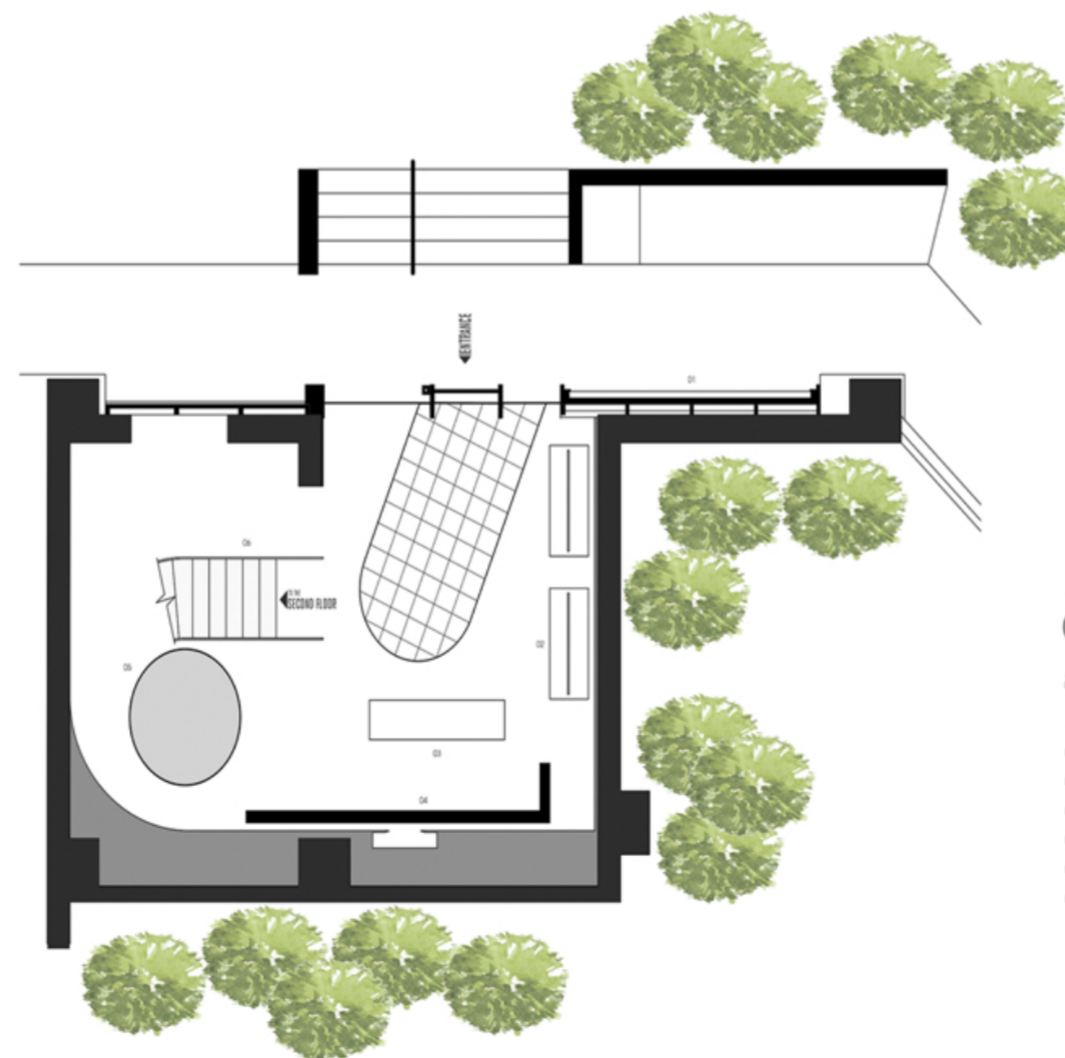

- GROUND FLOOR PLAN
- 01 LIGHT BOX
 - 02 PLATFORM
 - 03 FRONT DESK
 - 04 BACKGROUND WALL
 - 05 WATER DISH
 - 06 SPIRAL STAIR



A large area of pink will bring an excessive sweet taste to the space.

MATERIALS

Main materials are concrete, ceramic tile, steel My modern metropolis polished concrete flooring



A white spiral staircase serves the "Communicating device" between floors and spirals up in the pink space. The outline of the stairs and ceiling is reflected in the circular sink below, like a metaphor leading to a pond by the garden steps.

In a space nearly nine meters high, several irregular concentric circles are inlaid on the ceiling to form a scene of drifting clouds in the sky.

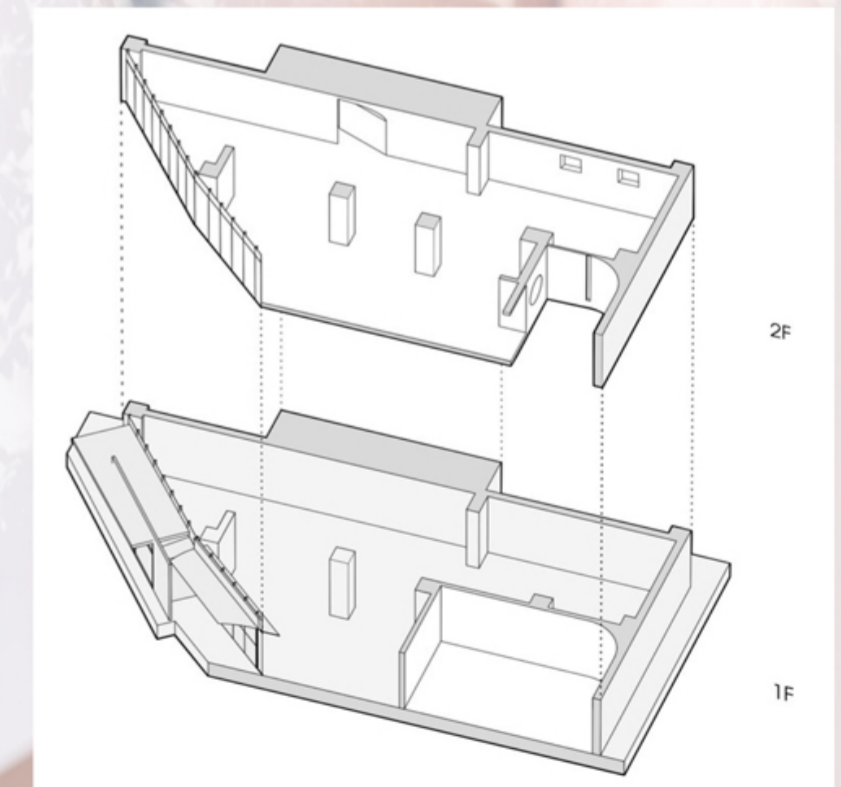

With a splintered circle, the space on the second floor was divided in to different functional areas, which presents the lay- out of a garden and forms two spatial relationships inside and outside.

The garden is raised overhead by steel str ucture and paved with red old bricks.At the top of it, largely identical pink blocks with minor differences are misaligned to

corresponding to the theme.



In the view of spiritual status of art in space, large paintings of women were selected and hung in the store which were soft, emotional and in pink tones. as a work that was selectrdath the be- ginning of the design, Modigliani Port- rait of jennie perfectly integrated with the whole.



In the search for materials with pink elements they were intrigued by the old ceramic bricks for construction in southern fujian. In the addition to its simple style and pink appearance the- re was also the implication of "stones from other hills."

The transom of the exterior wall was removed and replaced with transparent glass, which not only brought more transparent views but also made full use of natural light and views inside and outside.

The window next door was rented to widen the front of the store. Through the integrat ion of lateral ramps, the conversion of interior & exterior spaces, on the ground floor w as effectively organized. The green glass rem- oved from the old windows was made into a counter on the ground floor to complement the color scheme of the space.



By a T-shaped passage extending from the center, the garden is deconstructed and divided again, while areas of different heights & functions inside & outside are connected.In this way, different layers are formed among different areas, and the tra- nsformation of layers is accompanied by that of the functional areas.

In addition, the undulating surface creates a "sense of hilly area" similar to chinese ga- rdens, whereas obviously there are difference between the two.

All the way to the second floor, there is a delicate light throughout the space.In spite that the windows are north facing there will be sunlight reflected from the curtain walls of two opposite buildings in turn, which will last for nearly three hours intermittently.As the street bustles with traffic, the sunlight is reflected by the car wind- ows before scattering on the wall if the store like films of stream of consciouness.With the typeface on the store windows being weaved in it as well, the light is flicking and giving a glimpse of the scene, as it to see flow of time.Just looking at the transformation of pink sh- adow, you can see it for a long time.



ELISSA STAMPA

FASHION DESIGN OFFICE



Elissa stampa fashion office conduct their work. and functions both as a work space and a production area. designer designs and makes their designed clothes.

LOCATION-

ISTANBUL, TURKEY.

Architects: Aks architect

Area : 360 m²

Year : 2018

Office entrance has wooden panels that acts as semi-opaque exhibition wall where the trendy colors of the year are exhibited. The entrance welcomes the visitors with a small waiting area that is enhanced by the usage of green shelves where the organic and natural attitude of the design office is displayed..

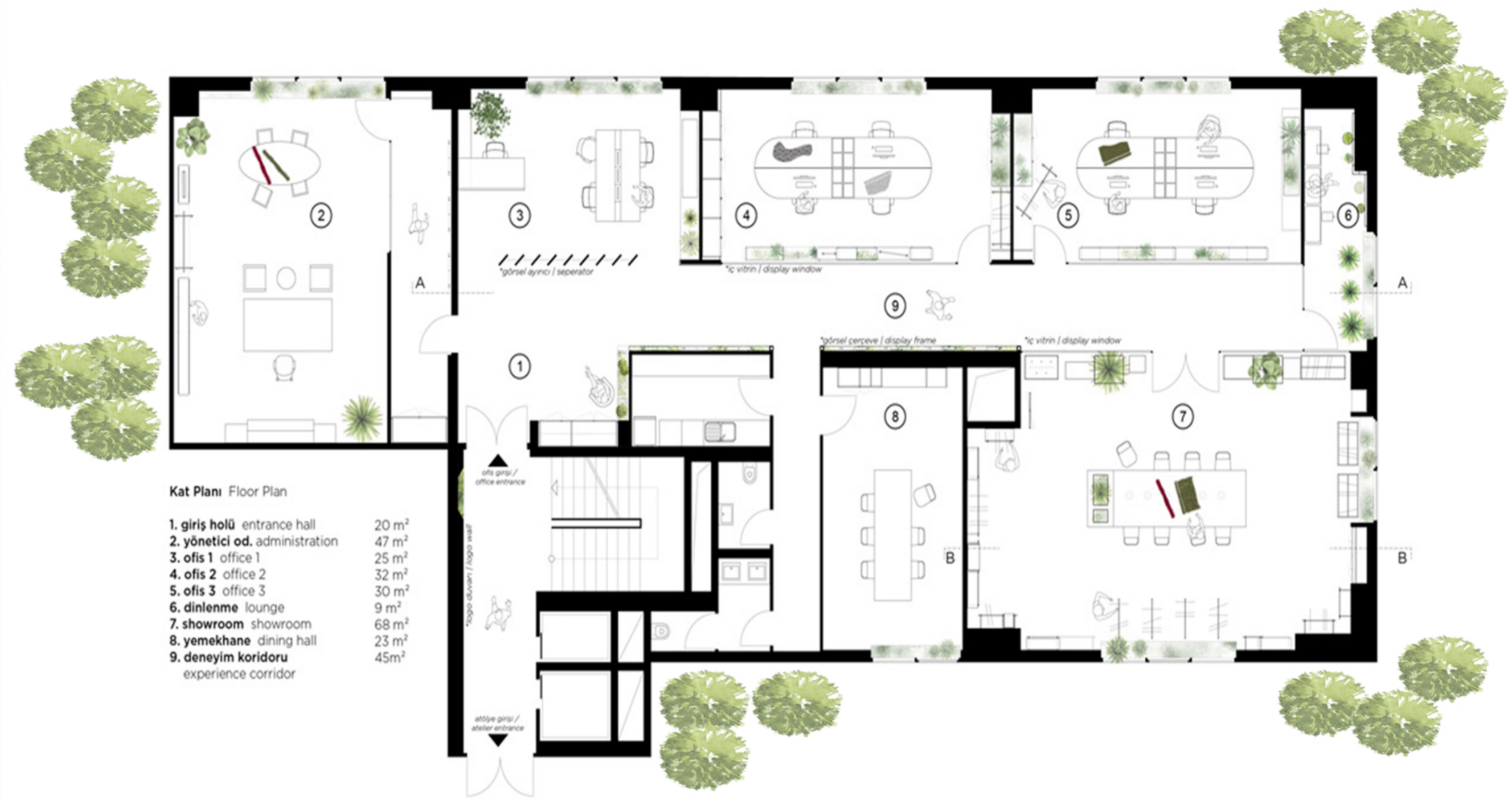

A Kesiti - Section A

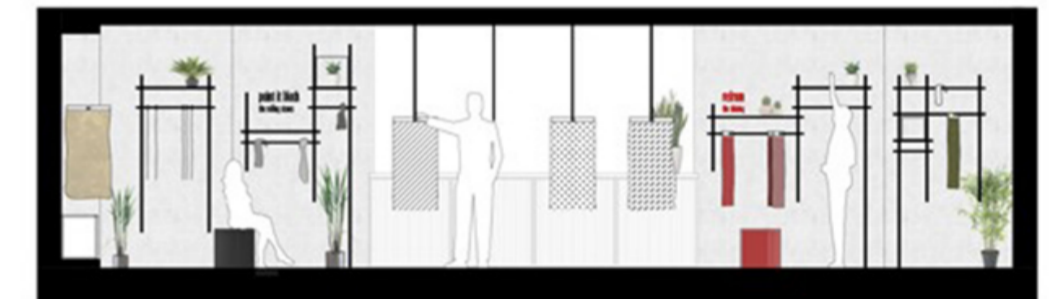

B Kesiti - Section B



LITERATURE CASE STUDY -2

ISTANBUL, TURKEY

Thesis submitted by Jumana nasrin.T, Reg No:209190045, Al Salama college of Interior Design

Main program of the office consist of two open office working areas and a showroom that acts as a meeting space. the open up the main circulation axis and divide the office into two. On one side the open-office spaces are located, and on the other side the service units and the main showroom space are planned. In the end of this main circulation corridor a chill out area is designed as a staff lounge.

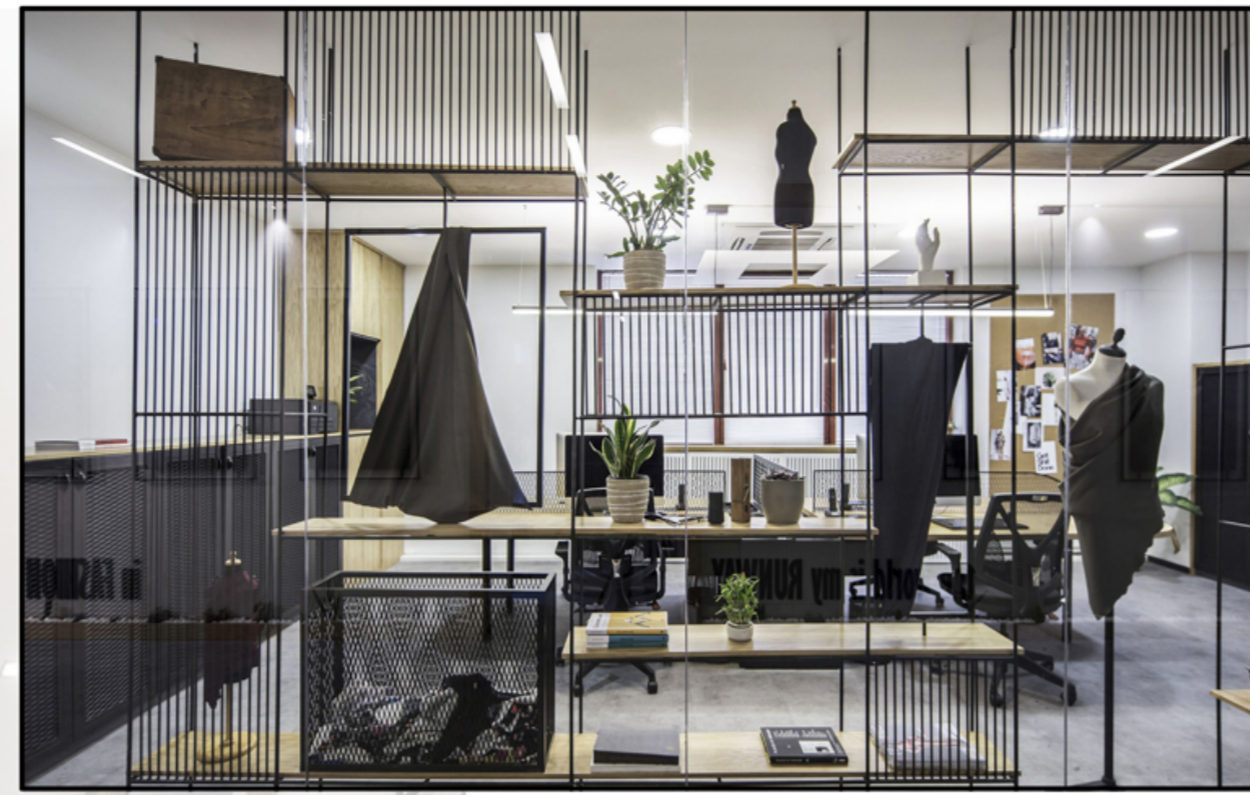

The circulation of the office is designed as an experience corridor, as all the main office program is left transparent facing this corridor. The open-office facades have semi-transparent bookshelves that can be dynamically modified through the usage of the office employees. They act as a window display for the office staff while at the same time they maintain privacy of the office interior. The bookshelves that have an elegant touch of natural wood and steel have features such as mirrors, frames, shelves and textile baskets which bring a functional usage to the separators. The vista of the employees have been refined with the integration of visuals.



The corridor we are encountered with the display window of the showroom, where all of the visitors of the office will experience. The space 18 designed to enhance the brand knowledge of the office creating a new corporate identity. Showroom is used to exhibit all of the textile charts designed by the textile office. The inner façade walls act as exhibition surfaces





SABYASACHI FLAGSHIP STORE

LOCATION:

Near qutub minar complex,
mehrauli, new delhi.

ARCHITECTS:

Sabyasachi Mukherjee

TYPE:

Flagship store

YEAR OF COMPLETION: 2008

AREA: 1250 SQM



Sabyasachi mukerjee operates through four flagship store in india and sell third party retailers world- wide, known for his bespoke bridal wear, the label offores beautiful master piece worn by famous bol-lywood and hollywood celebrities with collabrotation with chri-stain louboutin, pottery barn and forevermark,Sabyasachi has already established his name in the gobal market Despite of his fame in the fashion industry, he does not have platform to offer his product and servies in the US.This project aim to lunch sabayasachi mukerjee store and establish his presence in the US, will open door to the brides to recieve the exceptional servies offered to sabayasachi bride and with incoporates with a different culture to attract the non indian audience as well.

CONTEXT

Plain site near to qutub minar complex. Ideal site for the project can easily pull the tourist. The proj ect is located on main road. The site is surrounded by many other flagship store of indian famous designer.

CLIMATE

- Humid sub tropical
- Average temperture rangesfrom 19-32 depending on the weather
- Summer are hot, winter are quite cold, with most amount of rain during mansoons

CONNECTIVITY AND ACCESS

- Indira gandhi International Airport 12 km
- Bus Stand 1 km
- Railway Station: 12km

PLANING/ DESIGN OF THE SPACES

Nostalgia is always important factor in all his work, it plays a huge role it has all trational qajar art of persia to the victorian influence of to the dimly lit corridors the lavish display of his evolution every thing is summerized in all of his opulence store.

He believes in showcasing the real stories of indian art and craft to the world. Sabyasachi's flagship store in New Delhi is a royalmatch made in fashion and decor heaven, rare tanjore paintings, vintage dutch plates, sabyasachi for nilaya by asian paint wallpaper all of it add intreset to the pa- latial space.

The project is divided into two wings bridal and non bridal with grand stair- way in the middle of two wings. The layout of the store is straight layout. Straight floor plan makes optimum use of wall and utilise the space in the most judicious manner straight floor plan creates space within the retail store for the customer to move freely.



fig .Grand stairway used for photoshoot drop

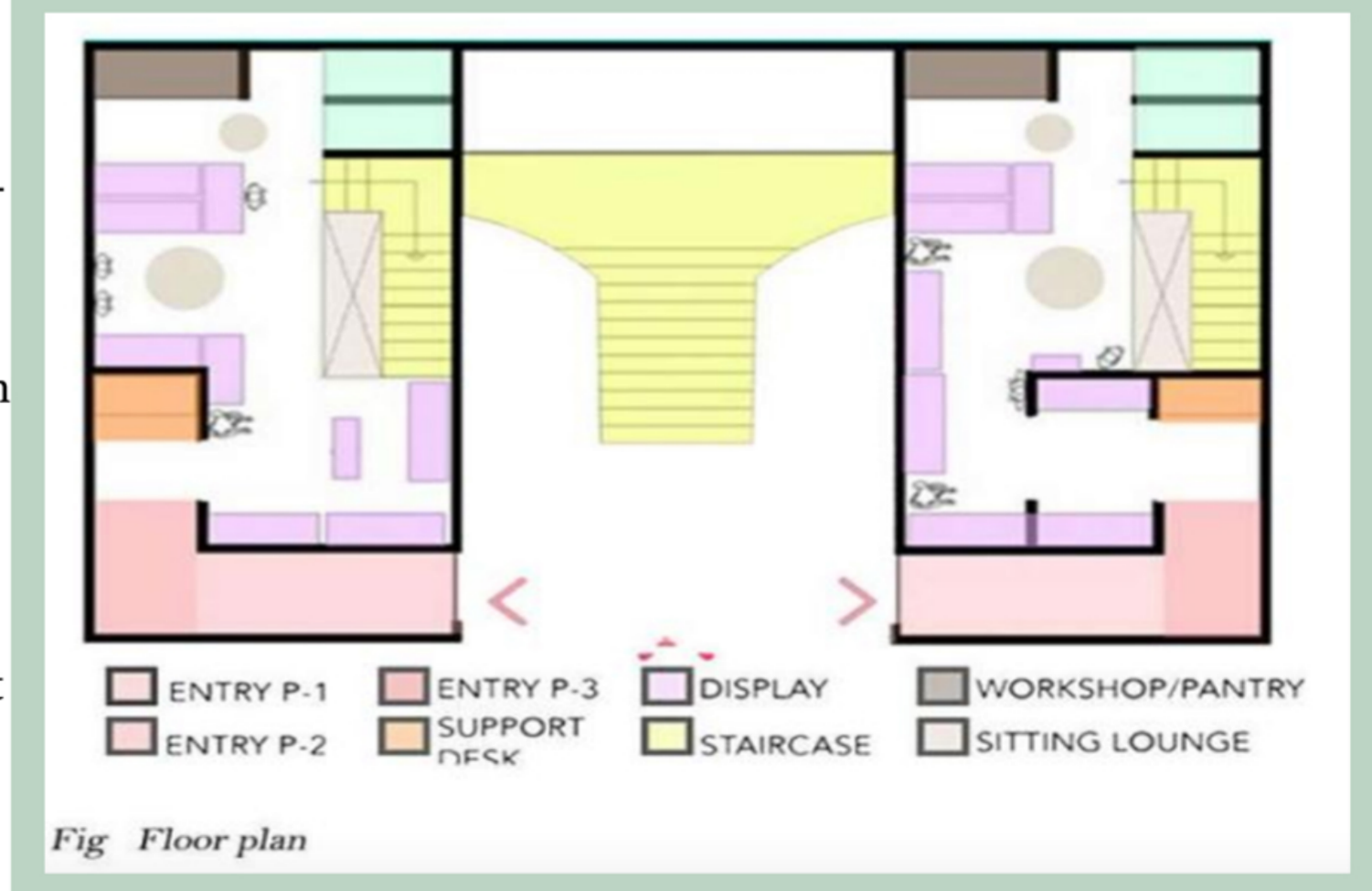
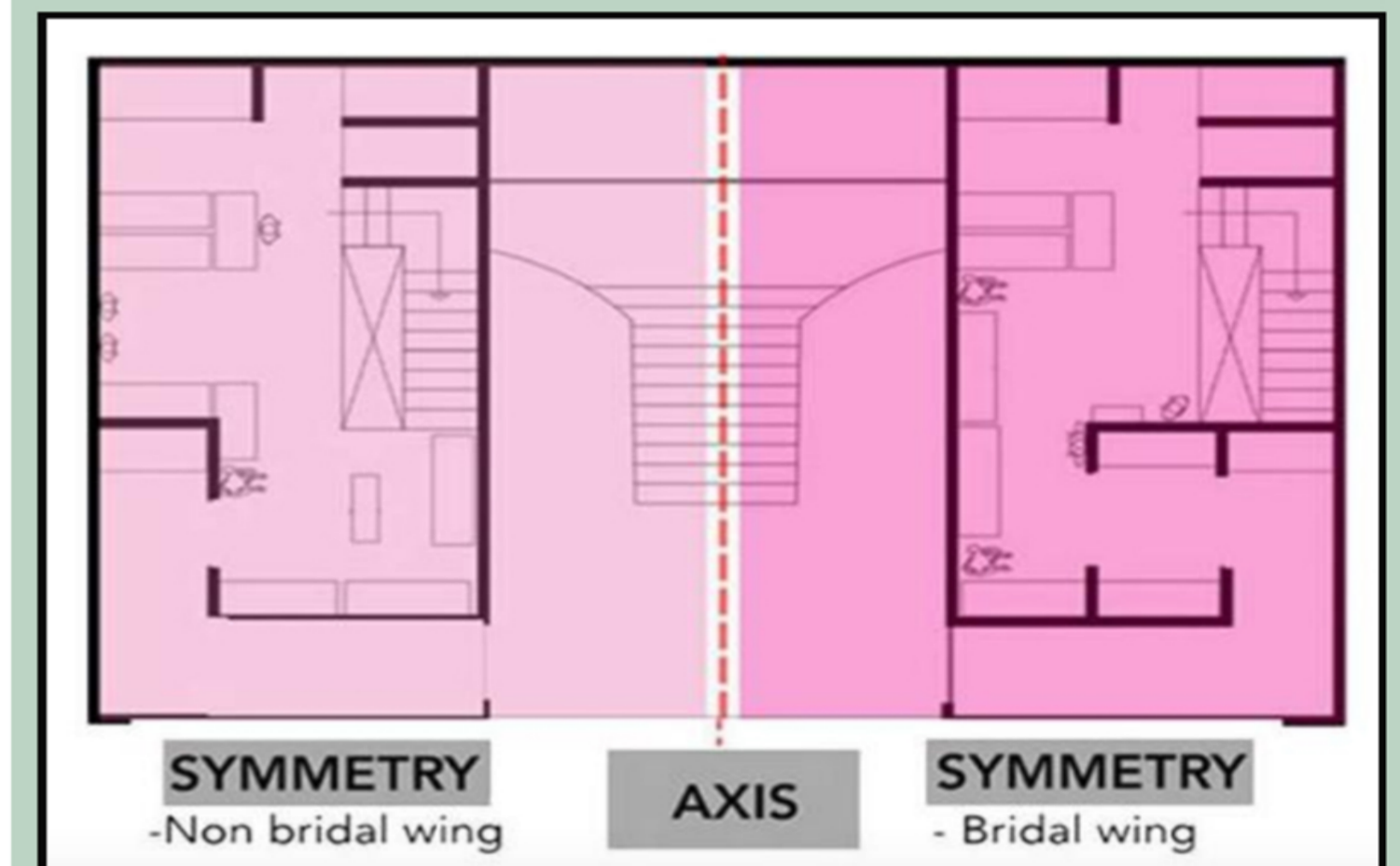

EXTERIOR

The exterior has a simple symmetric design, plain white color facade made of stone. The grand entrance something that comes to eyes first unique and attractive.

INTERIOR

In numbers the gorgeous details of interior are even more incredible. The store has no natural light in its interior the whole store lit up with decorative chandeliers and the texture of wall, artifacts, carpet itself. The only flaw of this kind of light is with cleaning Indian heritage is celebrated in every corner. The grand staircase divides this 13500 sqft store into two wings. The store is adorned with 63 piece of art from the sabyasachi art foundation, 112 antique carpet, 42 piece of calendar art, 52 chandeliers 732 bottles of ittar.



Fig .Female display area

INFERENCE

One of the best designer store in india to look forward for any party wear.

Ideal site for the project can easily pull the tourist. The grand entrance something that comes to eyes first, unique and attractive. Interior experience make you feel royalty. Interior is decorated with light and indian traditional stuffs.

The customers will enter into an experiential store where they can experience the ambience through five senses.

The staffs and the designer sabyasachi mukarjee make every client satisfied with their beautiful and detailed designer product.



fig .interior lounge view



fig .interior view of entrance



fig .stairways area



fig .dressing room



fig .male display area

SABAYASACHI PRODUCTS



fig .clutch



fig .belt



fig .sheos



fig .saree



fig .sherwani



fig .lehenga

CONCEPT

Geometric patterns are a collection of shapes, repeating or altered to create a cohesive design.

THE PSYCHOLOGY OF SHAPES

Different shapes can evoke different meanings., the most common shapes—rectangles, circles, triangles, rhombuses, and hexagons—can be broken down into something like this:

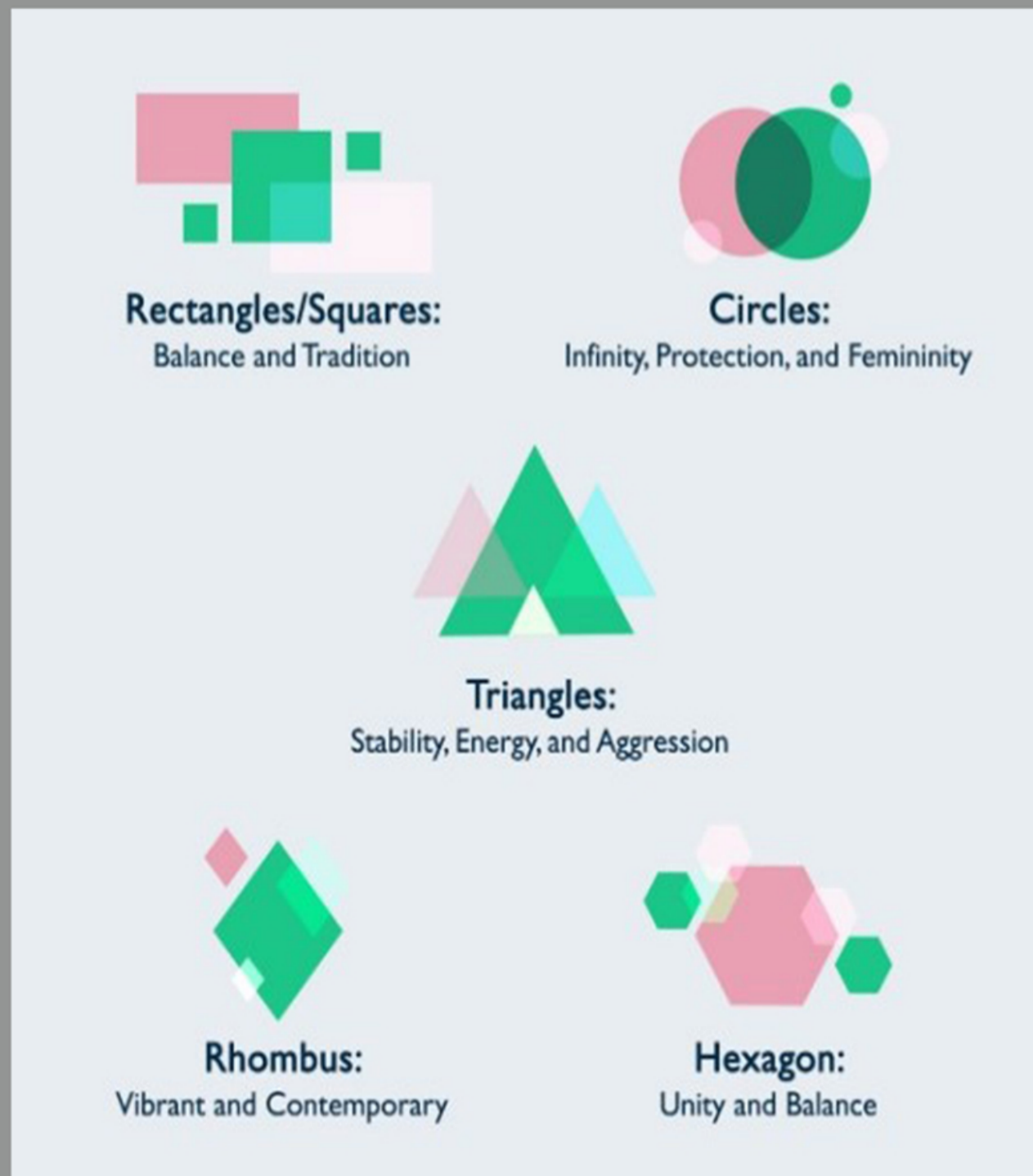

From among the shapes, the selected shape is rectangle . The psychology of rectangle is to have balance and tradition in design.the space and designs in the building is planned also according to the shape of rectangle thus the whole design is balanced .

DESIGN BRIEF

SPACES	NO OF PEOPLE	UNIT NO	TOTAL AREA
RECEPTION	2	1	112
WAITING LOBBY	11	1	144
DISPLAY AREA		1	384
MANAGER OFFICE	3	1	85
DIRECTOR OFFICE	3	1	123
SALON	7	1	178
DRESSING ROMM	3	1	102
SHOPPING AREA	10	1	309
STORAGE		1	273
WASHROOM	5	4	600
PHOTOGRAPHY STUDIO	3	1	227
CONFERENCE ROOM	11		246
LOCKER AND STAFFROOM		1	120
DECK AREA		1	1073
DESIGNER OFFICE	3	1	105
DESIGN STUDIO	10	1	387
IRONING & PACKING	4	1	172
TAILORING	6	1	289
FABRIC CUTTING	4	1	334
PAINTING AREA	2	1	180
EMBROIDERY	2	1	247
RESTURENT	21	1	501
FASHION ROOM	10	1	600
FASHION AUDITORIUM	10	1	2400

GF AREA : 6185 sqft
 FF AREA : 4196 sqft
 SF AREA : 4196 sqft
 TOTAL AREA : 14577 sqft

AREA

The Fashion design hub will accomodate all the activities within 14577 sqft

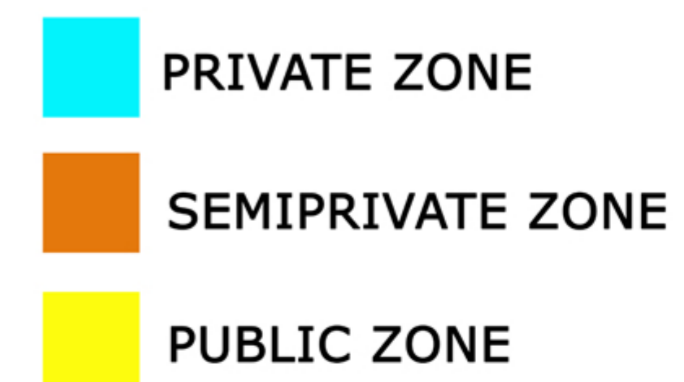
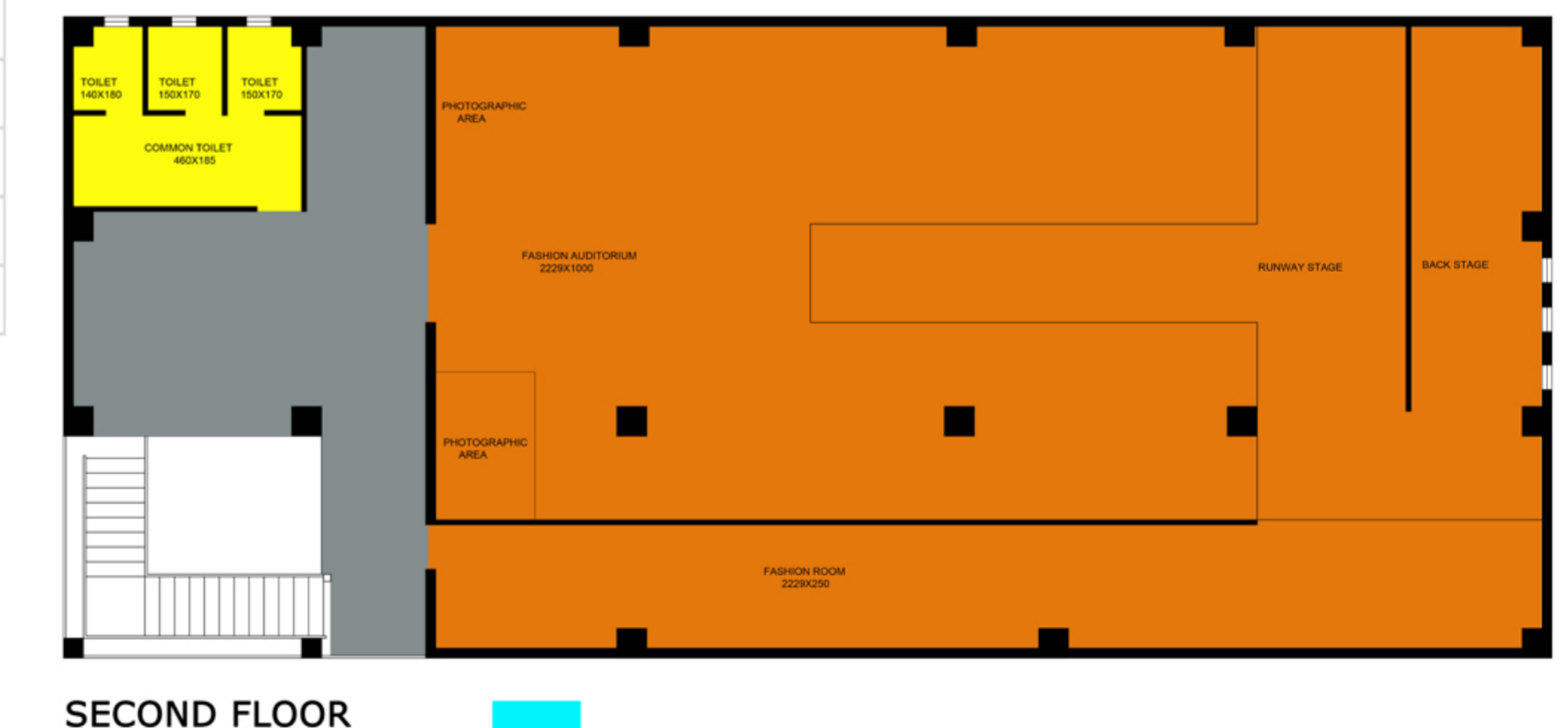
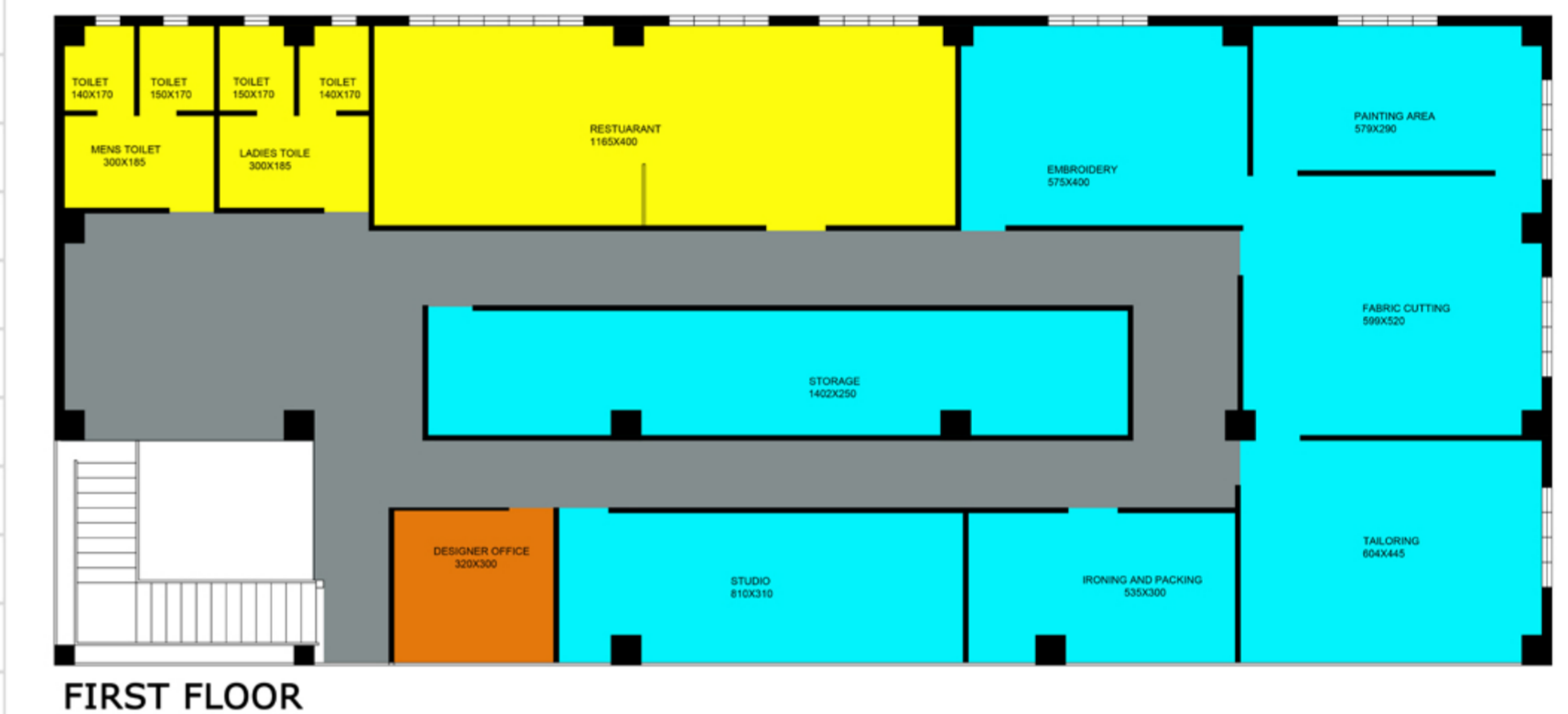

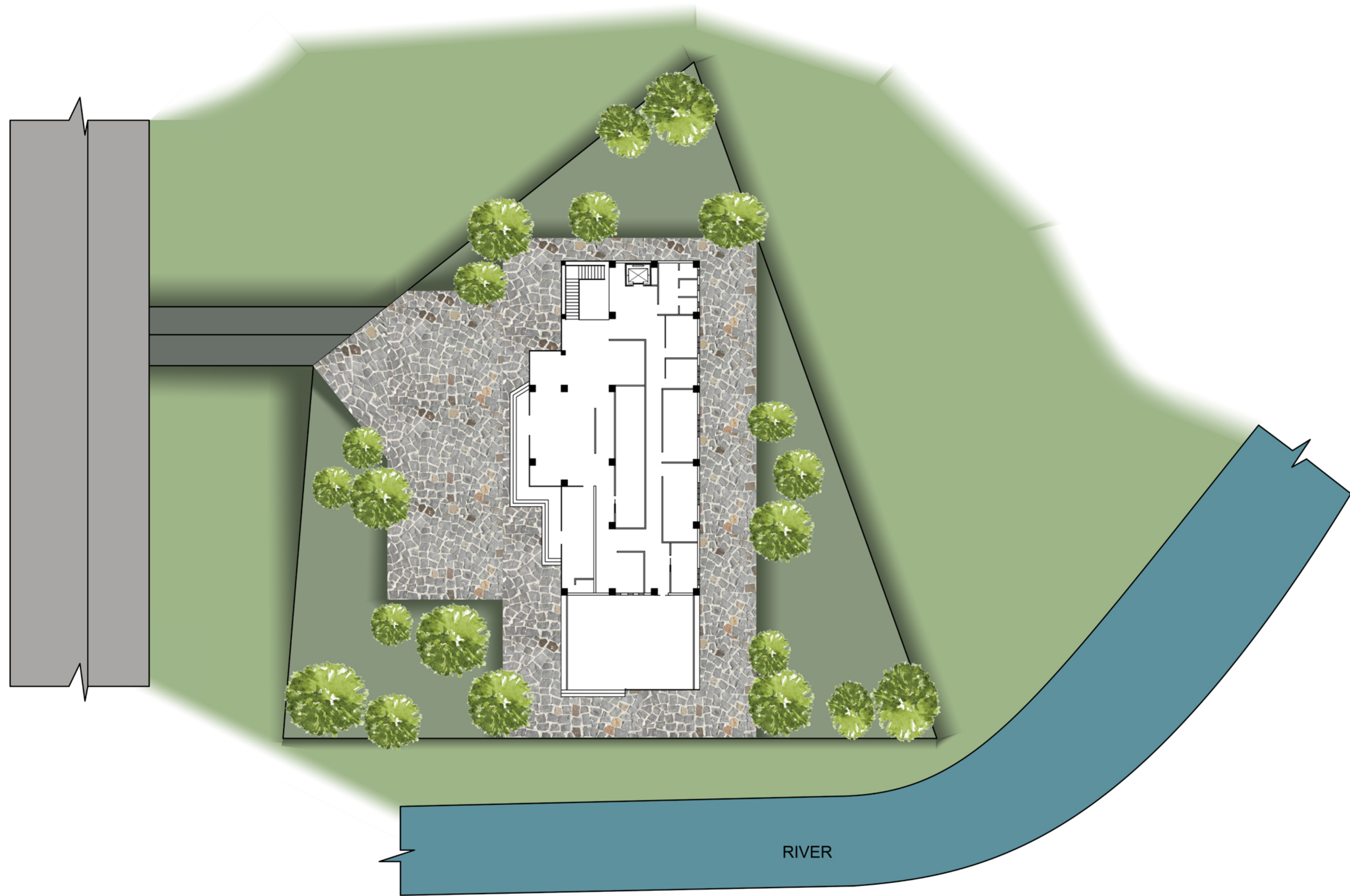

GROUND FLOOR PLAN

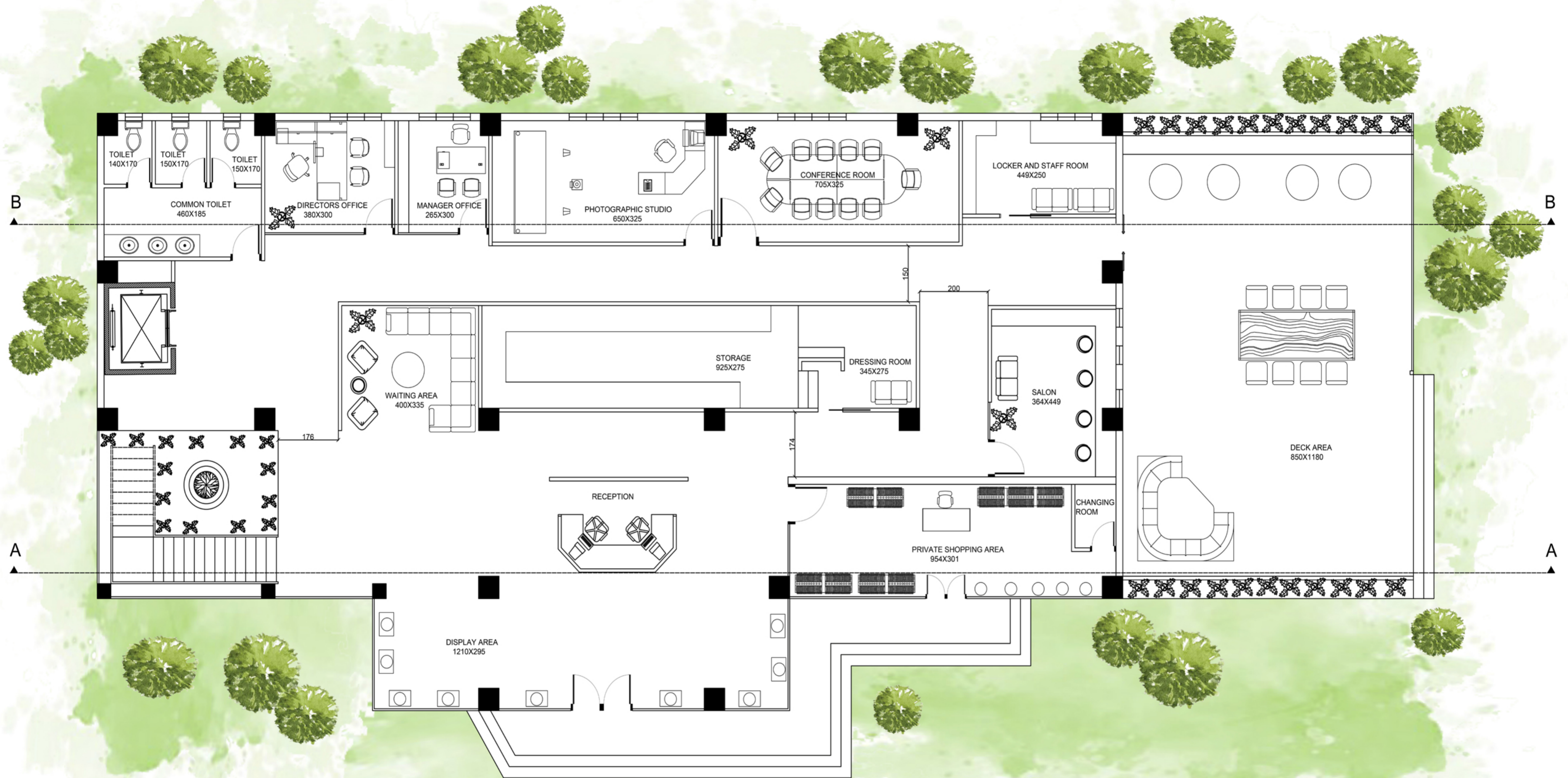

FIRST FLOOR PLAN

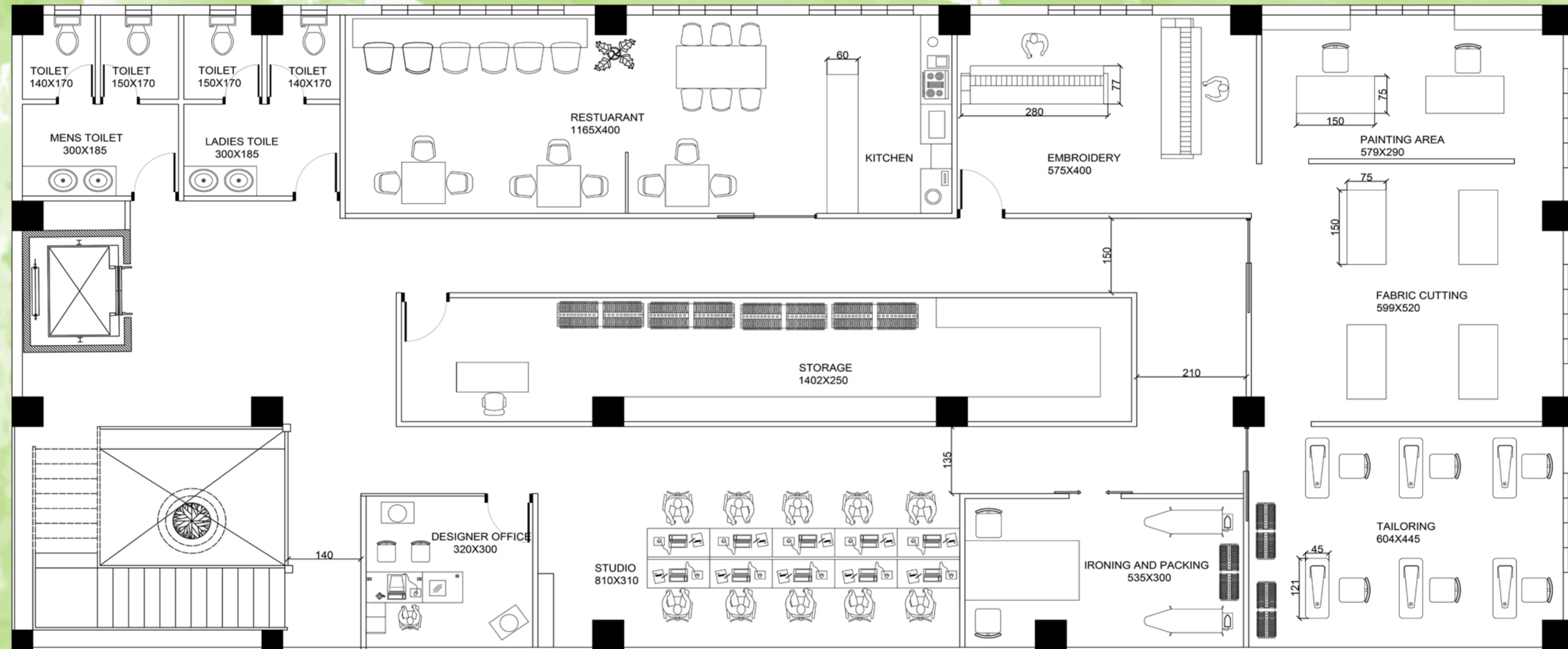

SECOND FLOOR PLAN

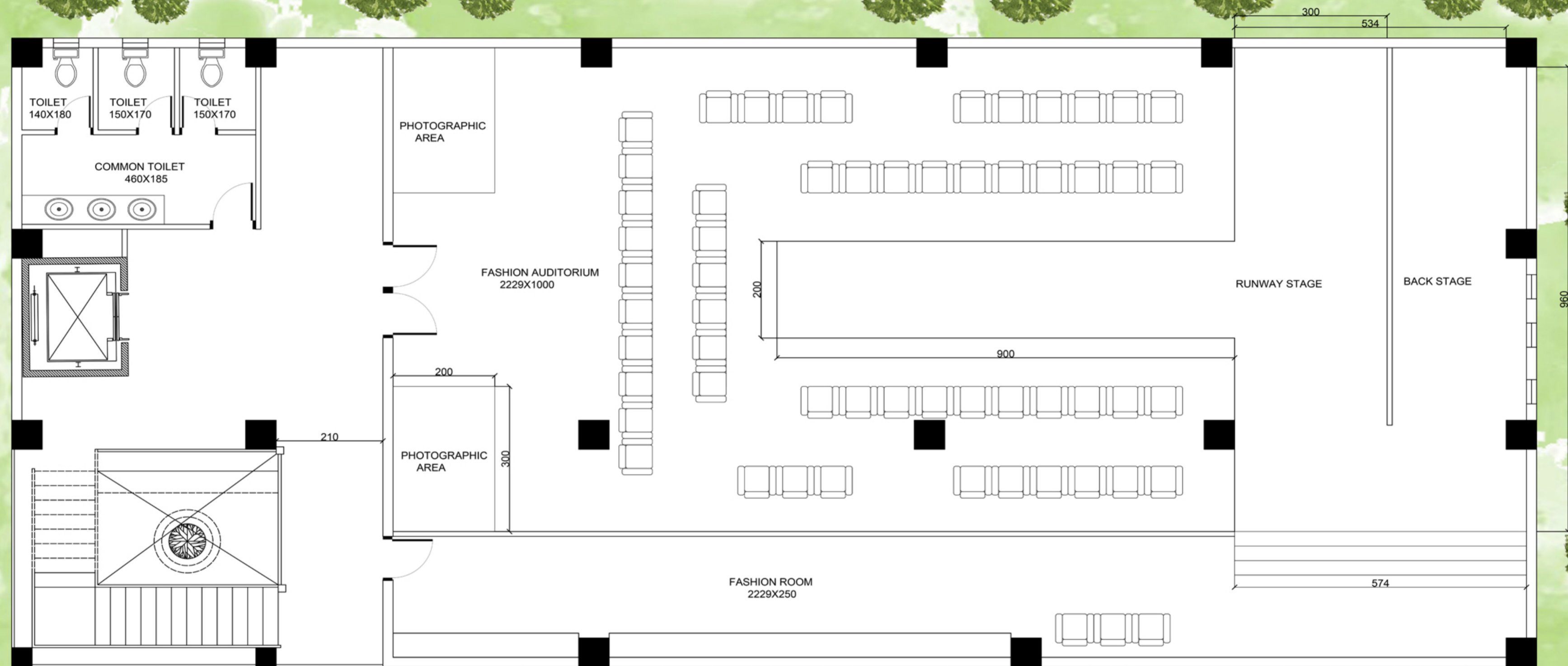

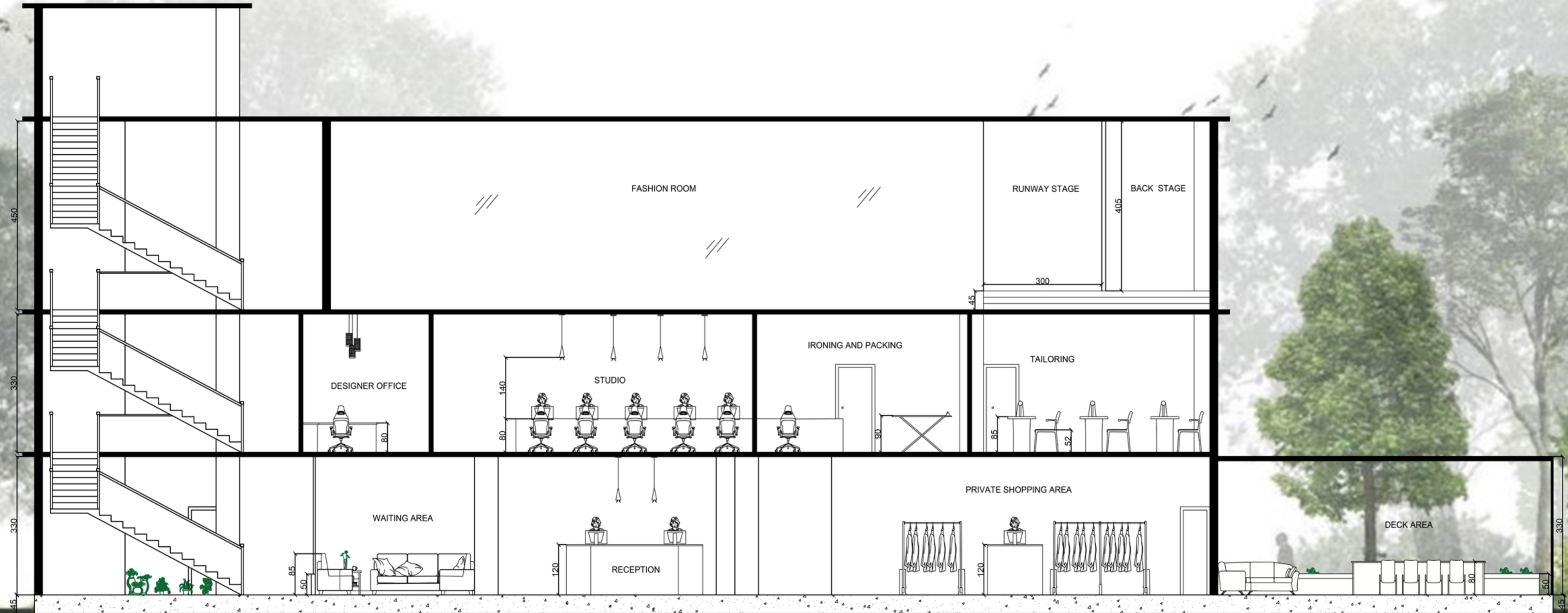

SECTION AA

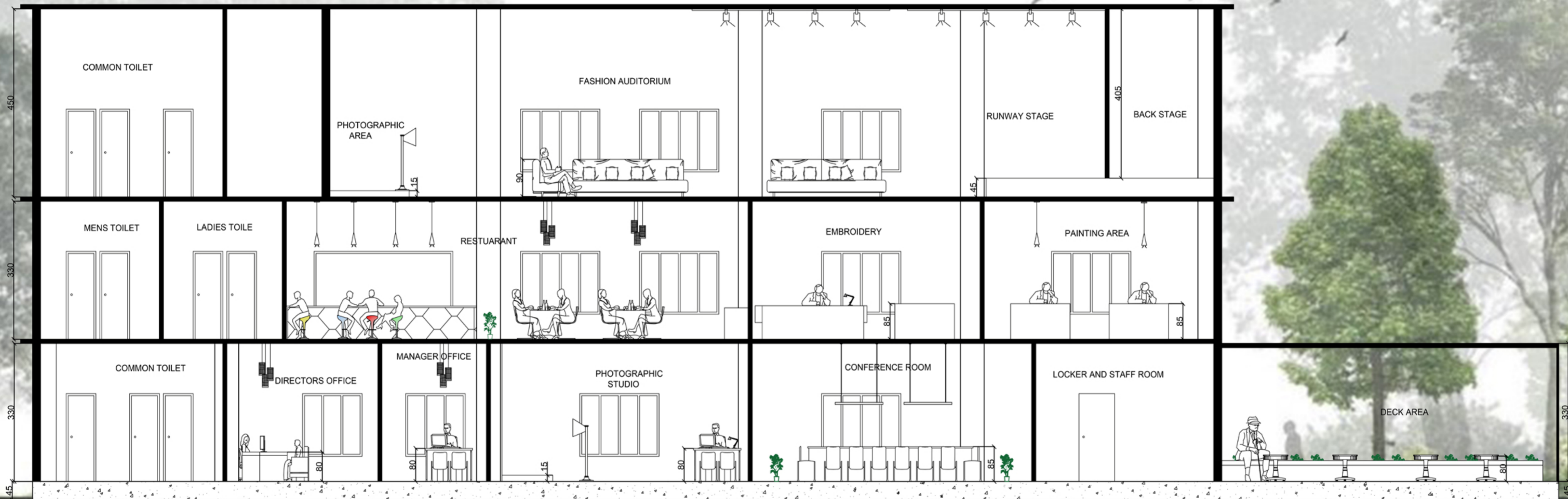

SECTION BB

FLOORING PLAN

GROUND FLOOR



THIRD FLOOR

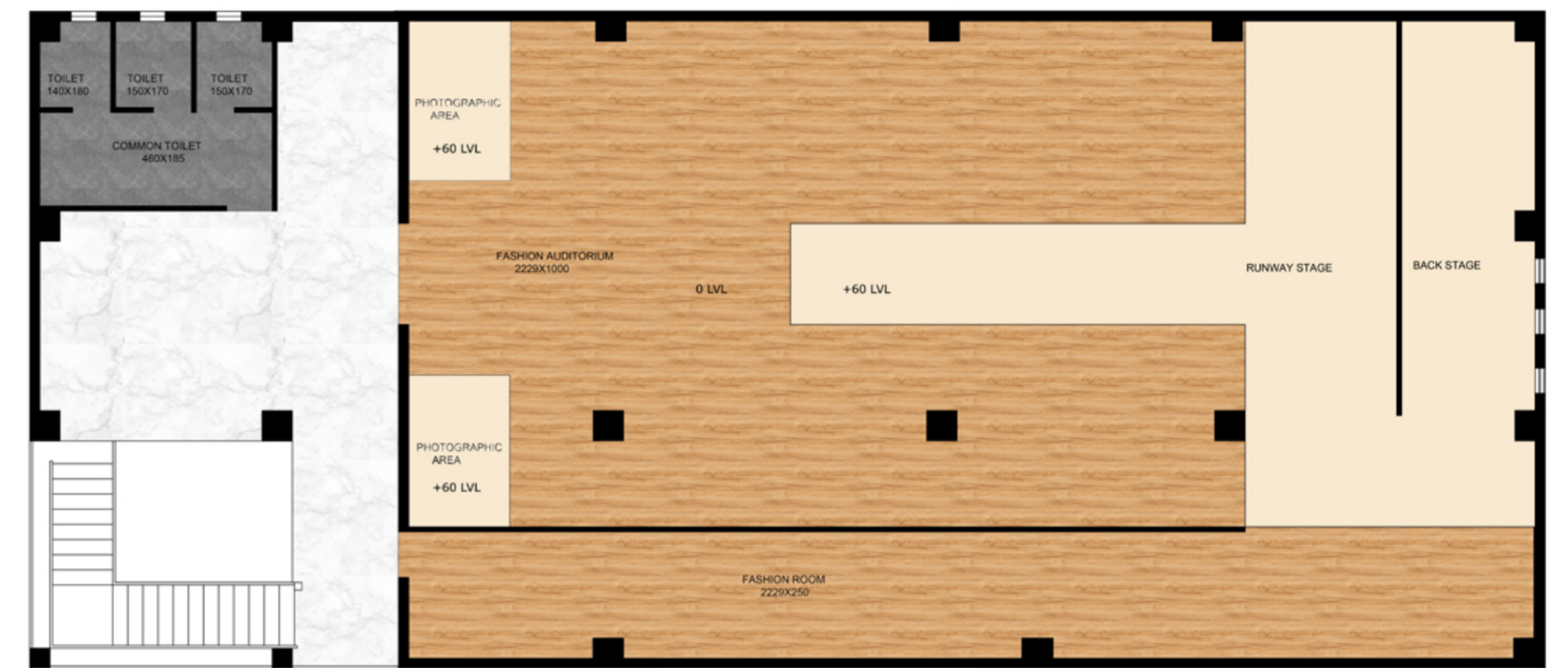

SECOND FLOOR

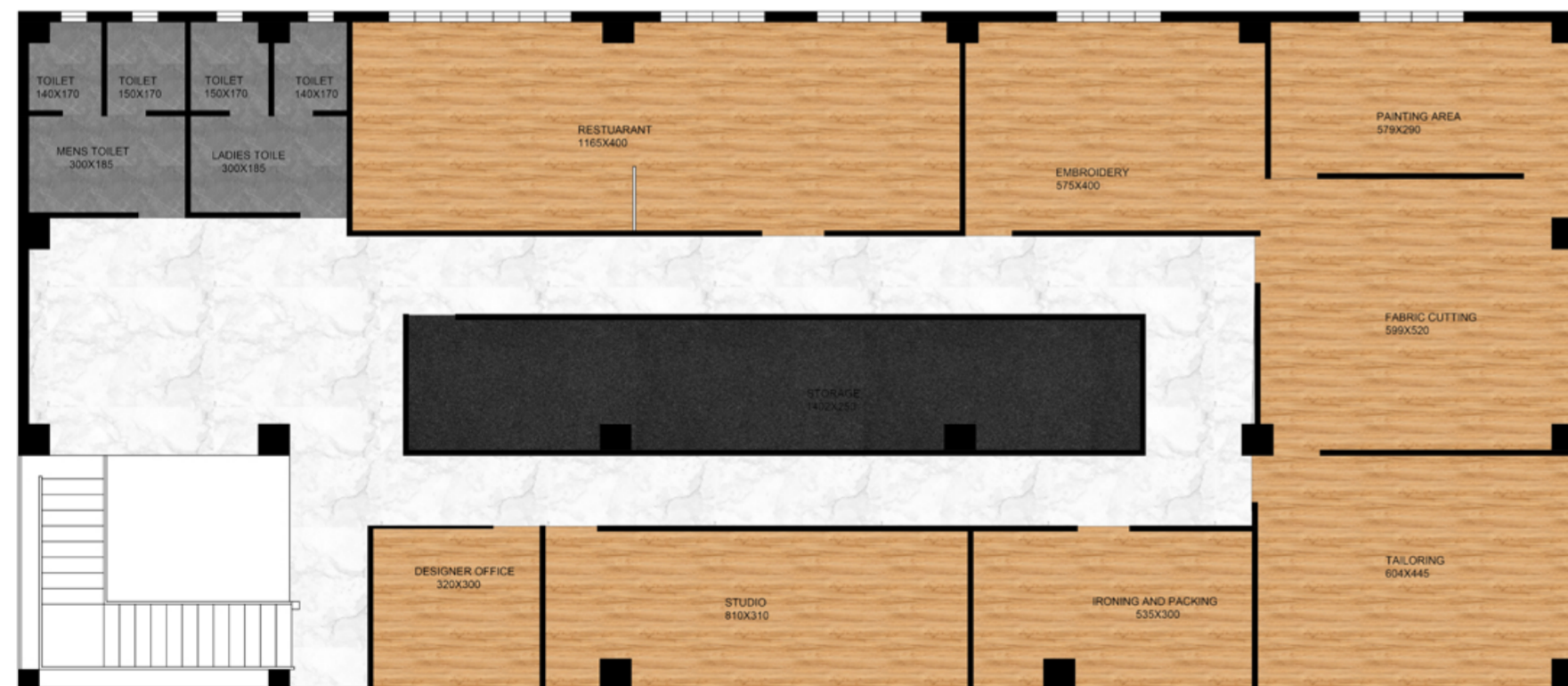

SPECIFICATIONS



TIMBER ROSE WOOD VITRIFIED TILE
 BRAND : KAJARIA
 SIZE : 60 X 120 CM
 FINISH : WOOD



EVENT HIGH GLOSS SHOW VINYL FLOOR
 FINISH : HIGH GLOSS

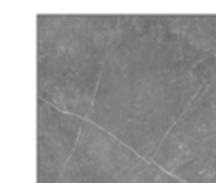

BUICK DARK VITRIFIED TILE
 BRAND : KAJARIA
 SIZE : 60 X 60 CM
 FINISH : MATT



MORWAD WHITE MARBLE
 BRAND : RK MARBLES
 SIZE : 60 X 60 CM
 FINISH : GLOSSY

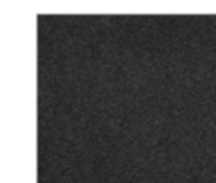

CARPET
 FINISH : FABRIC

CEILING PLAN

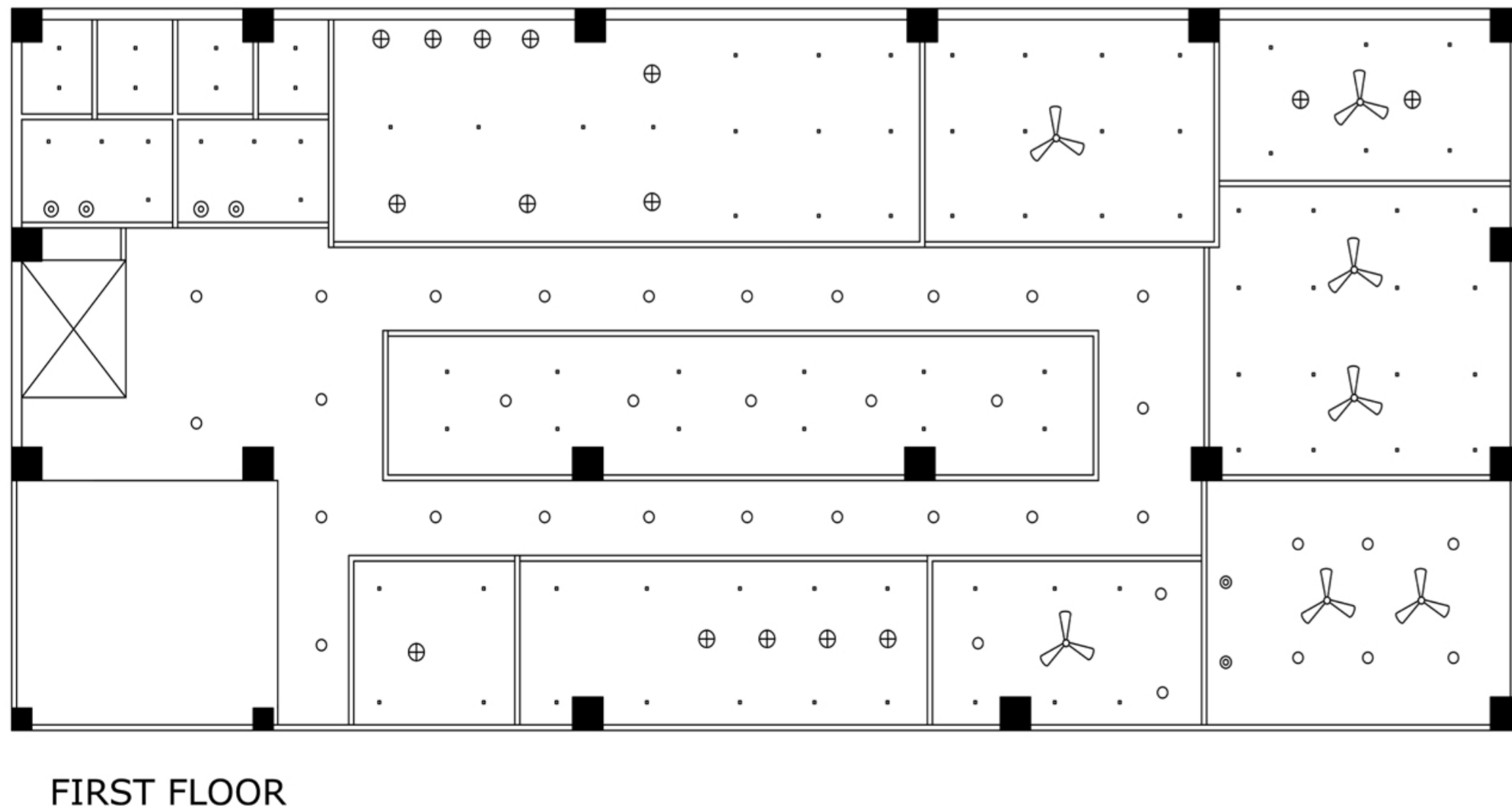
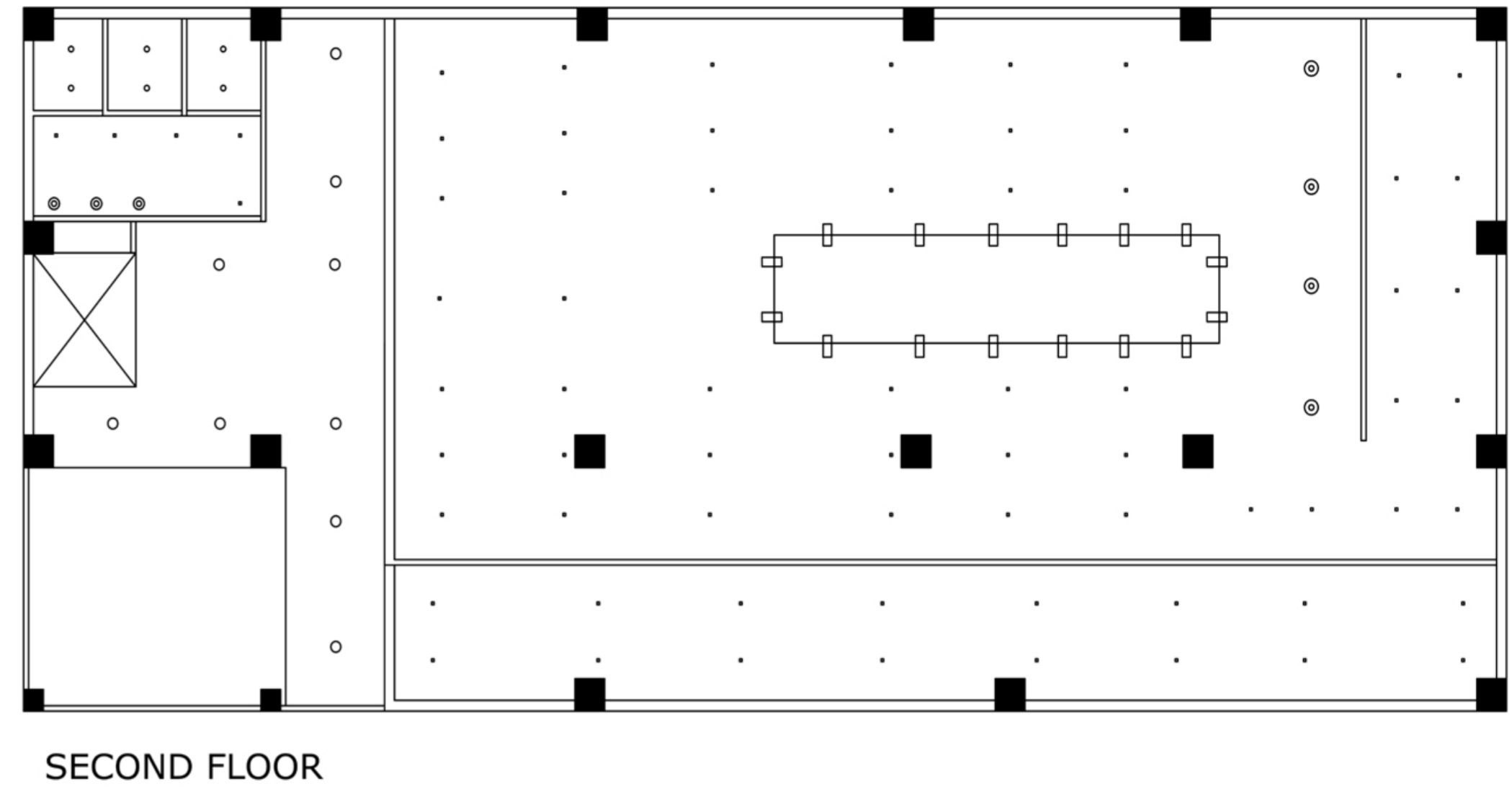
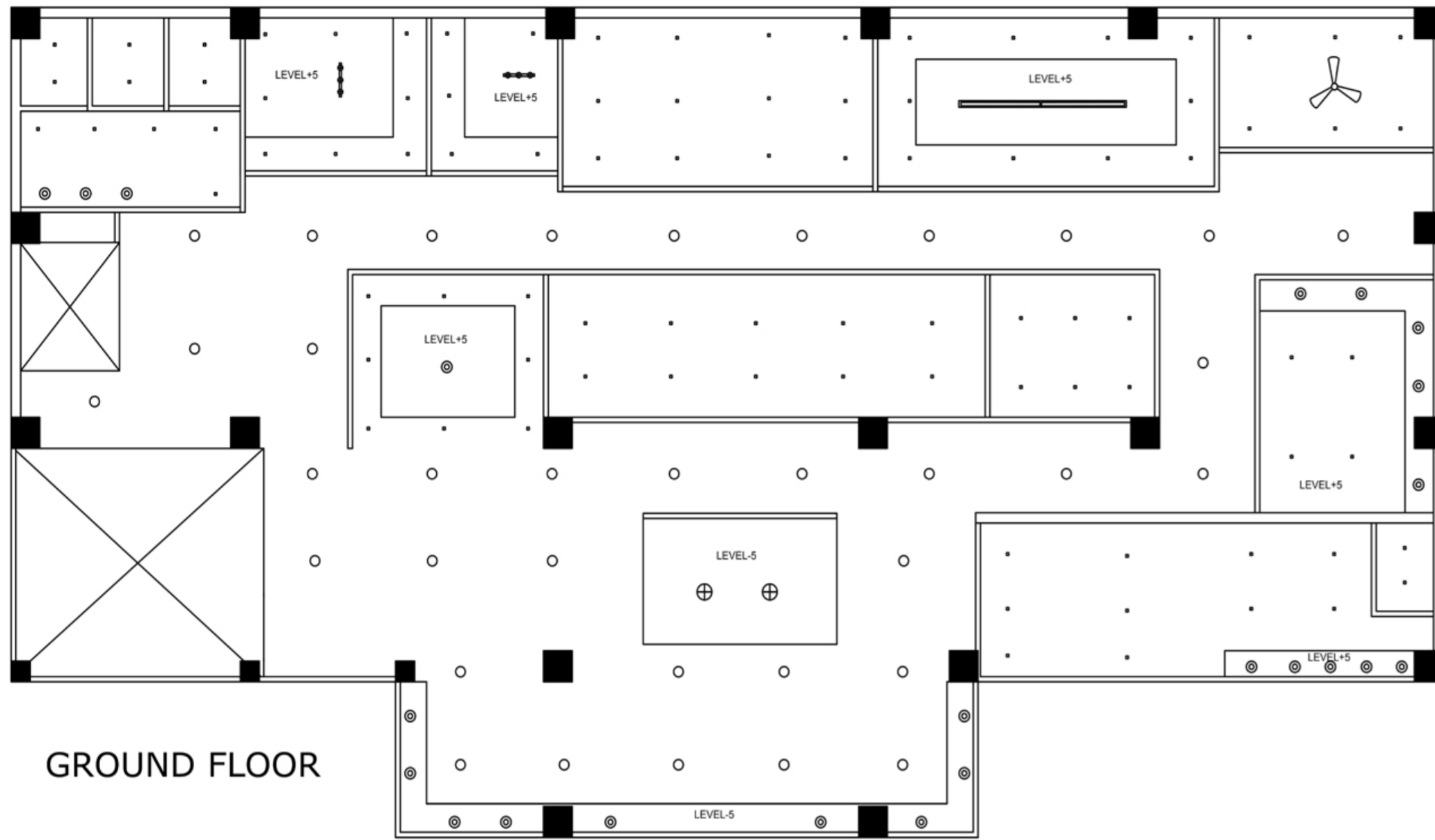

□ LED PANEL LIGHT
SQUARE,6X6,NATURAL LIGHT(4000K),12W

▭ STAGE LIGHT
130W,WARM WHITE,LED

○ LED SURFACE PANEL LIGHT
22W,WHITE

⊕ HANGING LIGHT

⊙ SPOT LIGHT
LED,WARM WHITE(3000K),12W

⊗ CEILING FAN

▭ LED HANGING PROFILE LIGHT
NATURAL WHITE(4000K),36W



LOBBY



PHOTOGRAPHIC STUDIO



DECK AREA



TAILORING ROOM



FASHION AUDITORIUM

